



För bästa prestanda ...

ANVÄND ENDAST ORIGINAL McCONNEL RESERVDELAR

För att vara säker på att alltid få senaste designförbättringar ska du köpa dina 'Original reservdelar' från din 'Maskintillverkare'

McCONNEL LIMITED

Ange alltid:

- ***Maskintyp***
- ***Serienummer***
- ***Beställningsnummer***

Designförbättringar kan ändra några av de delar som finns upptagna i denna handbok – delar i senaste utförande kommer alltid att levereras om de är utbytbara mot ett tidigare utförande.

1,2 M MULTICUT FYRDUBBEL DRIVNING

McCONNEL

Moduler: 7354851, 7354866, 7354871 (avbildad), 7354863, 7354883

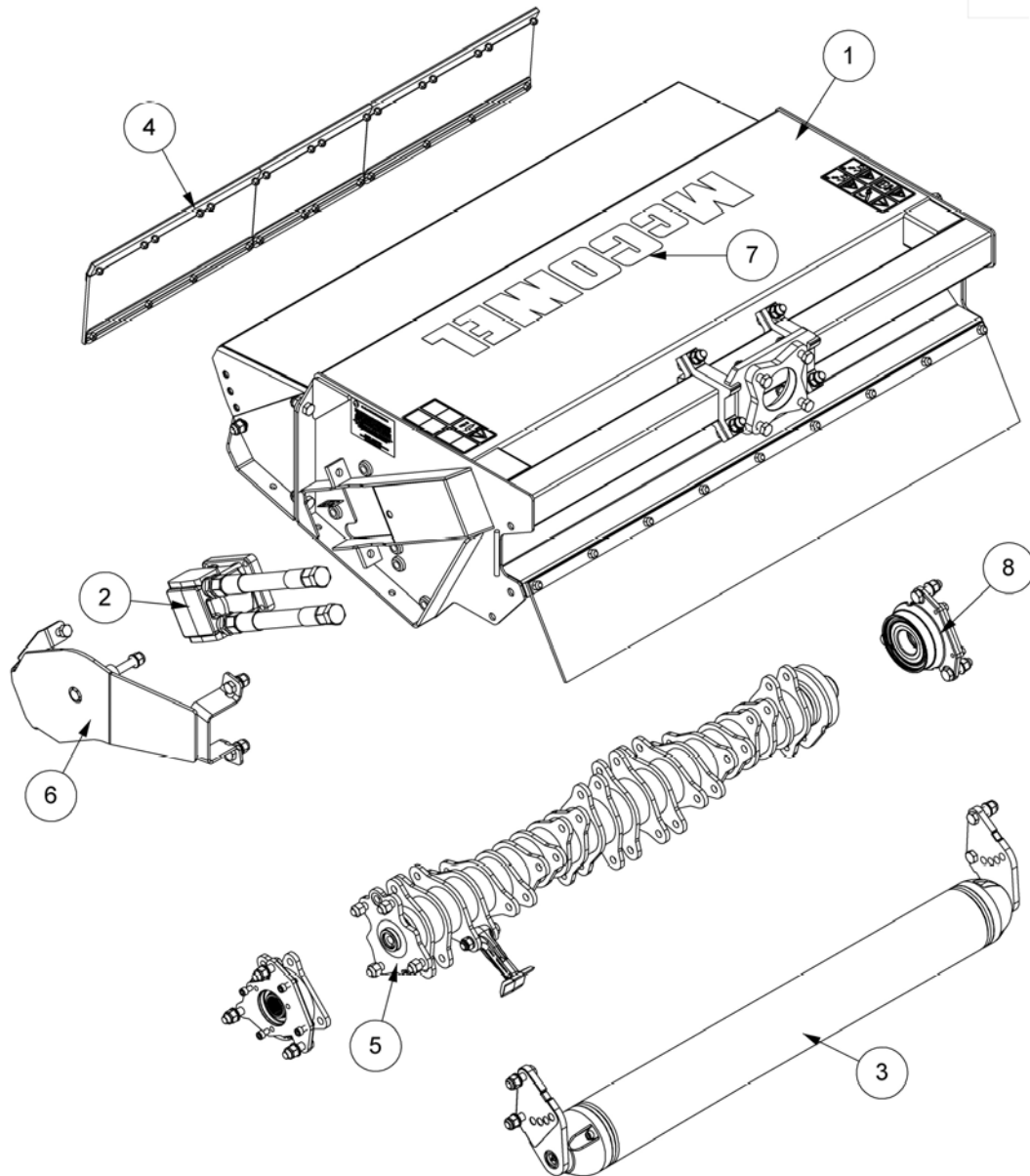

REF.	ANTAL	BEST.nr	BESKRIVNING
		7354851	1.2M MULTICUT 54HP FLAILHEAD
		7354871	1.2M MULTICUT 65HP FLAILHEAD
		7354866	1.2M MULTICUT 45HP FLAILHEAD (JIC Build)
		7354863	1.2M MULTICUT 54HP FLAILHEAD (OMEGA)
		7354883	1.2M MULTICUT 65HP FLAILHEAD (OMEGA)
1	1	22494.05	1.2M DD FLAIL HEAD CASING MODULE
2	1	22495.05	125LPM DRIVE MODULE - 65HP
	1	22495.06	100LPM DRIVE MODULE - 54HP
	1	22495.16	75LPM DRIVE MODULE - 45HP
3	1	21523.08	1.2 DMS ROLLER
4	1	7290375	FRONT FLAP KIT
5	1	22497.01	1.2m QUAD DRIVE ROTOR MODULE
	1	22497.07	1.2m QUAD DRIVE ROTOR MODULE (OMEGA)
6	1	22496.03	LH COVER MODULE
7	1	7350709	DECAL MODULE
8	1	22498.03	MULTICUT QUAD DRIVE MODULE

1,2 M KLIPPHUVUD HUS KOMPLETT

McCONNEL

Moduler: 22494.01 (version 85 hk), 22494.05 (version 65 hk)

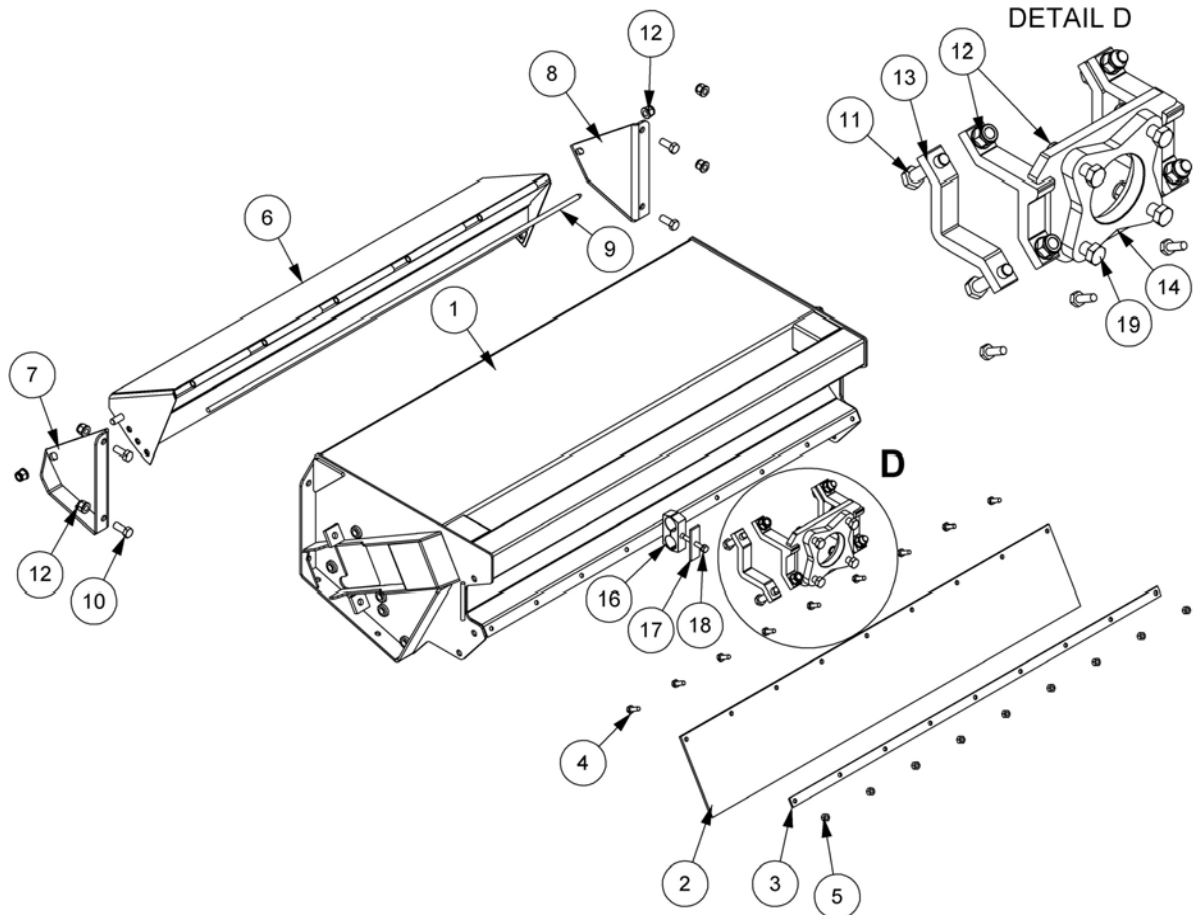

REF.	ANTAL	BEST.nr	BESKRIVNING
		22494.01	1.2M FLAILHEAD ASSEMBLY (85HP D/Drive)
		22494.05	1.2M FLAILHEAD ASSEMBLY (65HP D/Drive)
1	1	41685.03	1.2M HEAD CASING (85HP Build)
	1	41685.01	1.2M HEAD CASING (65HP Build)
2	1	7190314	REAR FLAP
3	1	7190313	CLAMP STRIP
4	9	9313065	SETSCREW
5	9	9163005	CLEVELOC
6	1	41695.02	FRONT HOOD
7	1	7290388	LH HOOD BRACKET
8	1	7290387	RH HOOD BRACKET
9	1	41700.01	HINGE PIN
10	6	30.073.25	BOLT
11	4	12.714.75	BOLT
12	14	9100024	SELF-LOCKING FLANGE NUT
13	2	7198332	CLAMP
14	1	7198330	CLAMP
15	1	9100205	SPRING WASHER
16	1	7193063	PIPE CLAMP (PAIR)
17	1	06.418.05	CLAMP PLATE
18	1	9213145	BOLT
19	4	9210167	BOLT

1,2 M KLIPPHUVUD HUS (HYDRAULISK HUV)

Moduler: 22494.69

McCONNEL

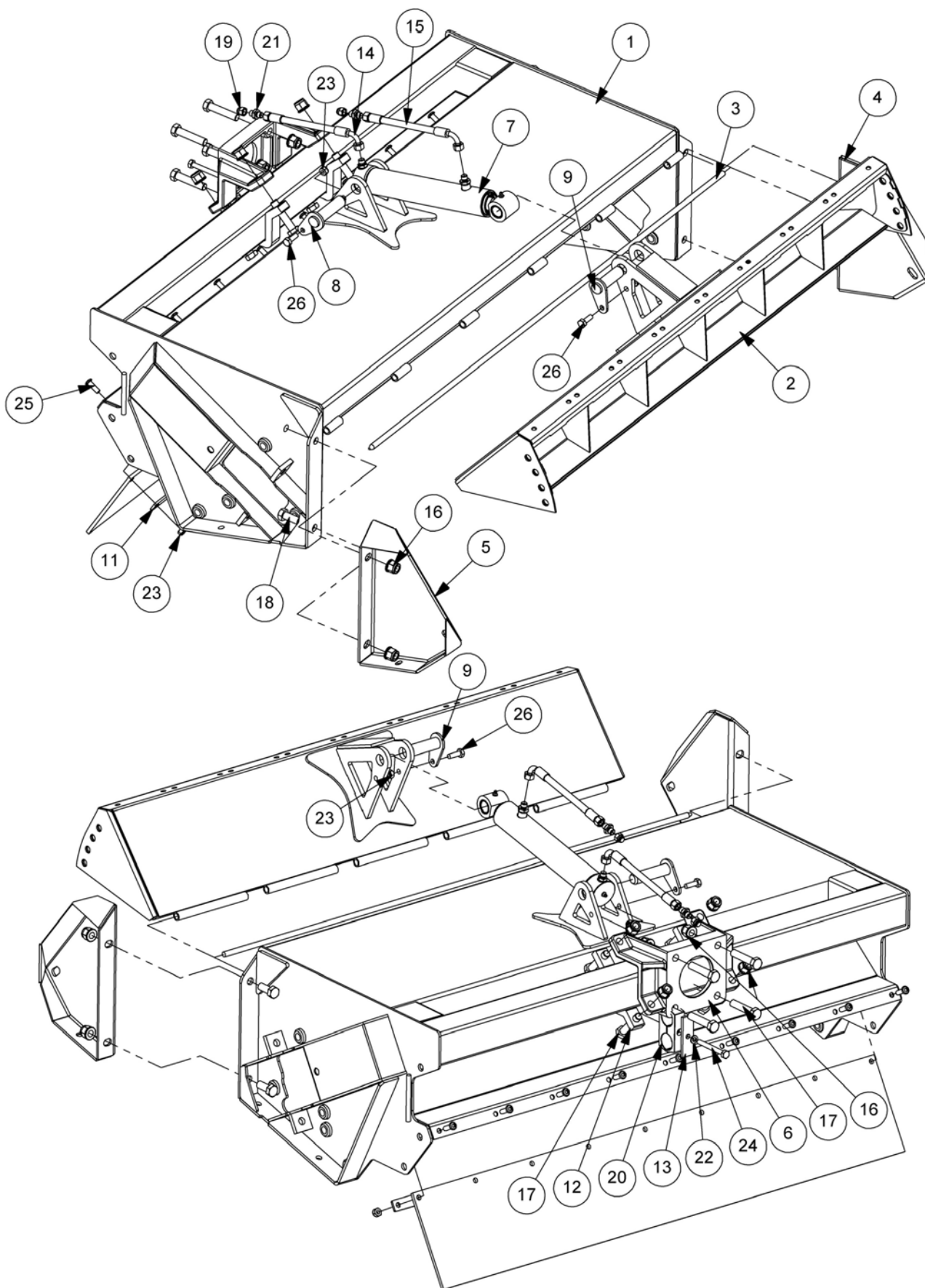

REF.	ANTAL	BEST.nr	BESKRIVNING
		22494.69	1.2M HYD. HOOD HEAD CASING ASSEMBLY
1	1	41685.10	1.2M HYD.HOOD CASING
2	1	41695.11	1.2M FRONT HOOD c/w RAM MOUNTING
3	1	41700.01	HINGE PIN
4	1	22492.11	LH HYD HOOD CHEEK PLATE
5	1	22492.12	RH HYD HOOD CHEEK PLATE
6	1	22748.01	HEAD CLAMP BRACKET
7	1	23693.01	HYD.HOOD RAM ASSEMBLY
8	1	41267.03	PIN
9	1	41267.12	PIN
10	1	7190314	REAR FLAP
11	1	7190313	CLAMP STRIP
12	2	7198332	CLAMP
13	1	06.418.05	CLAMP PLATE
14	1	10.002.34	HOSE - 1/4"BSP FS/F90 x 2400mm
15	1	10.002.37	HOSE - 1/4"BSP FS/F90 x 2700mm
16	12	9100024	S/LOCKING FLANGE NUT
17	8	12.714.75	BOLT
18	4	30.073.25	BOLT
19	2	520560	BLANKING CAP
20	1	7193063	PIPE CLAMP (PAIR)
21	2	8581169	ADAPTOR
22	1	9100205	SPRING WASHER
23	11	9163005	NYLOC NUT
24	1	9213185	BOLT
25	9	9300166	BUTTON HD.SKT SCREW
26	2	9313065	SETSCREW

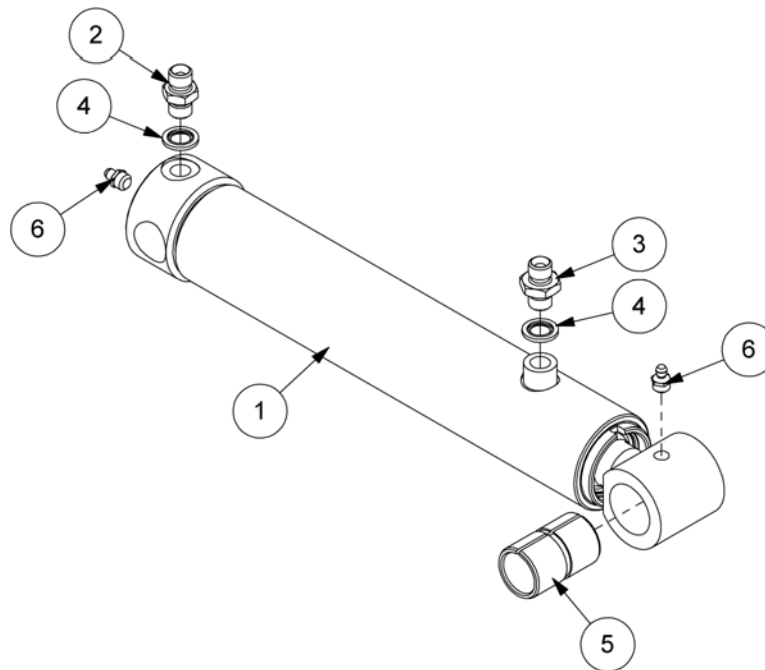

REF.	ANTAL	BEST.nr	BESKRIVNING
		23693.01	HYDRAULIC RAM ASSEMBLY
1	1	7560355AP	COMPENSATOR RAM
2	1	8130135	RESTRICTOR BLANK
3	1	8581169	ADAPTOR
4	2	8650102	BONDED SEAL
5	1	7105050	BUSH
6	2	0901121	GREASE NIPPLE

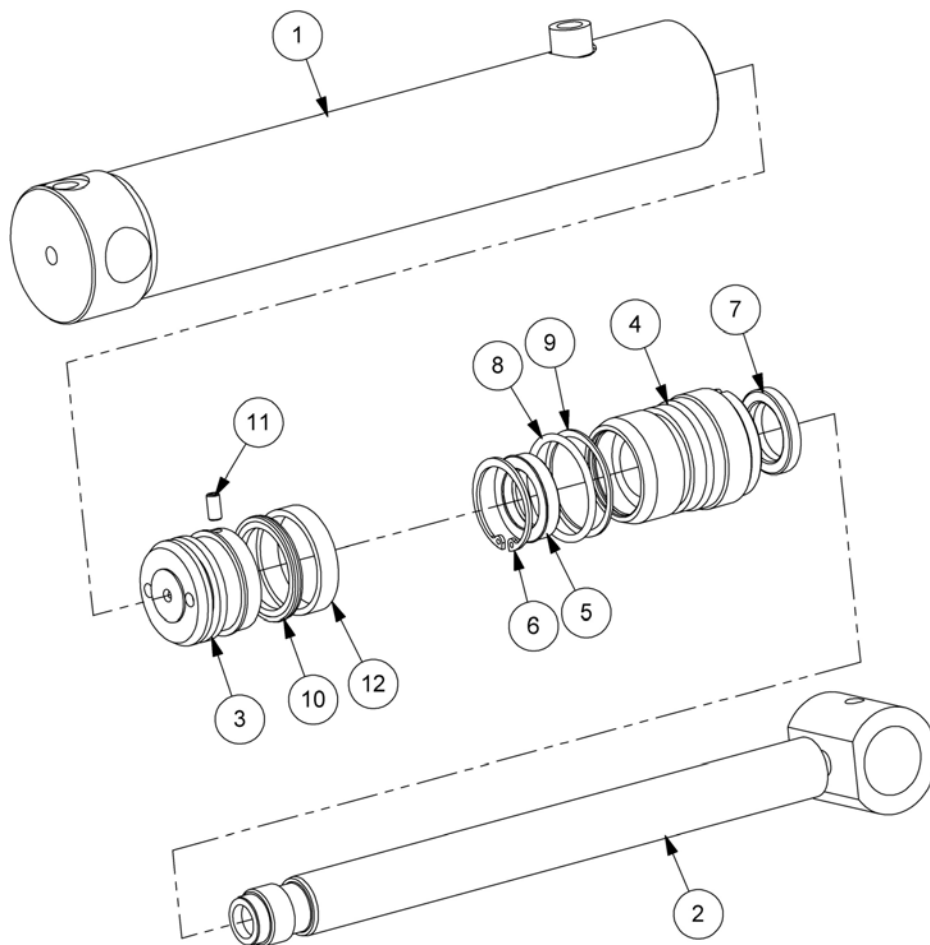

REF.	ANTAL	BEST.nr	BESKRIVNING
		7560355AP	RAM ASSEMBLY
1	1	7195305	RAM BARREL
2	1	7195010	PISTON ROD
3	1	7560095	PISTON
4	1	7135291	GLAND HOUSING
5	1	8629148	GLAND SEAL
6	1	416240	INTERNAL CIRCLIP
7	1	8629149	SCRAPER RING
8	1	8600302	O RING
9	1	8609302	AE RING
10	1	8629187	PISTON SEAL
11	1	9363023	GRUB SCREW
12	1	8629188	GUIDE RING

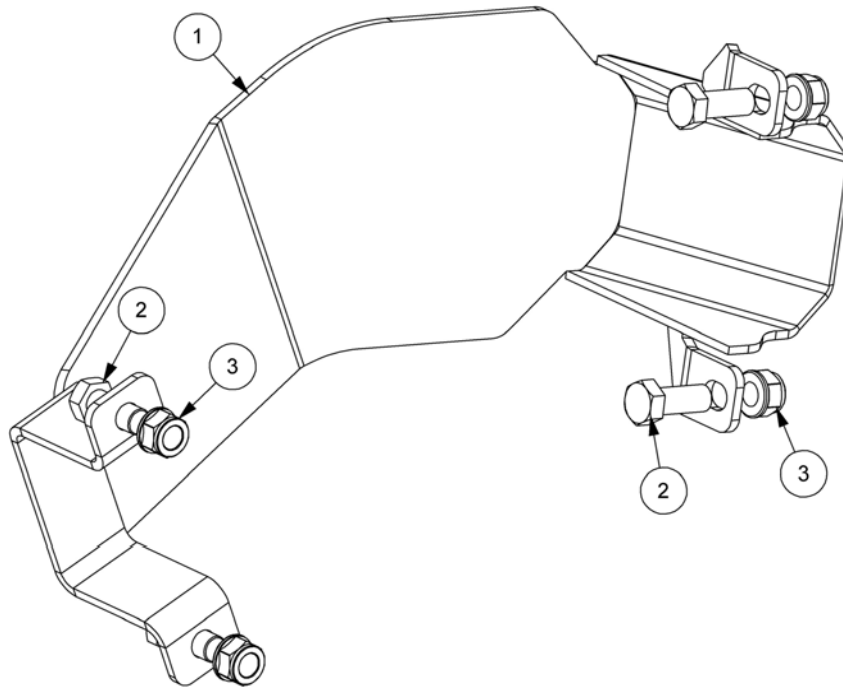

REF.	ANTAL	BEST.nr	BESKRIVNING
		22496.01	MOTOR COVER ASSEMBLY
1	1	42282.07	MOTOR COVER (L/H)
2	4	30.073.25	BOLT
3	4	9100024	SELF-LOCKING FLANGE NUT

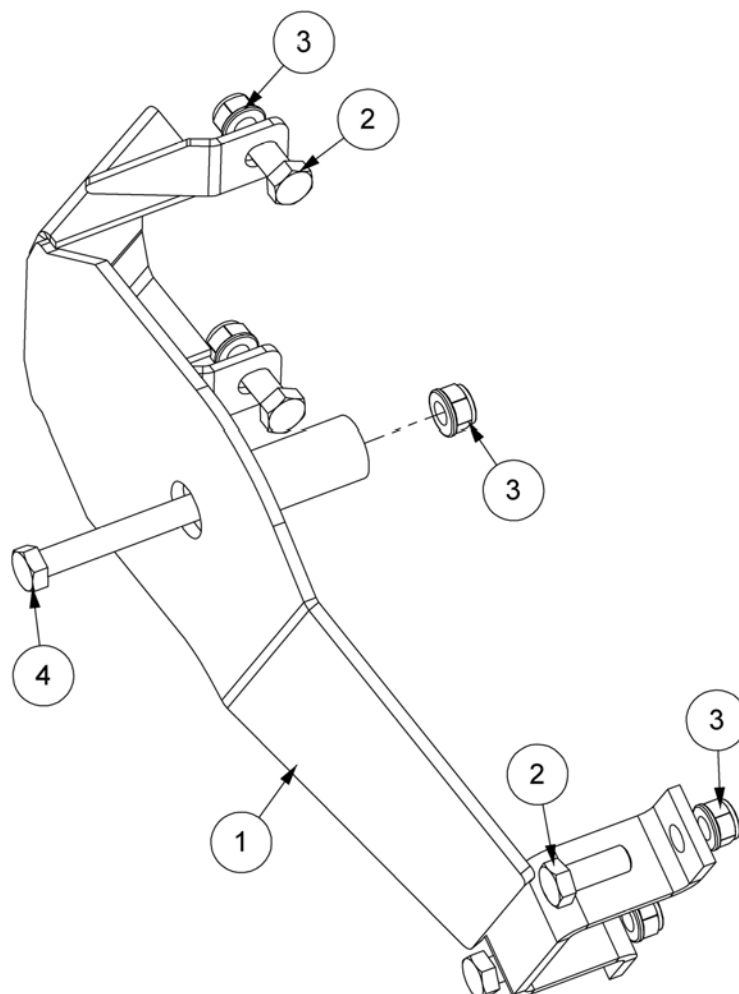

REF.	ANTAL	BEST.nr	BESKRIVNING
		22496.03	MOTOR COVER ASSEMBLY - L/H
		22496.04	MOTOR COVER ASSEMBLY - R/H
1	1	42282.03	MOTOR COVER - L/H
	1	42282.04	MOTOR COVER - R/H
2	4	30.073.25	BOLT
3	5	9100024	SELF-LOCKING FLANGE NUT
4	1	9200034	BOLT

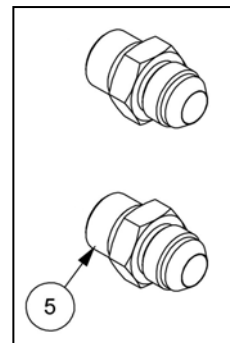
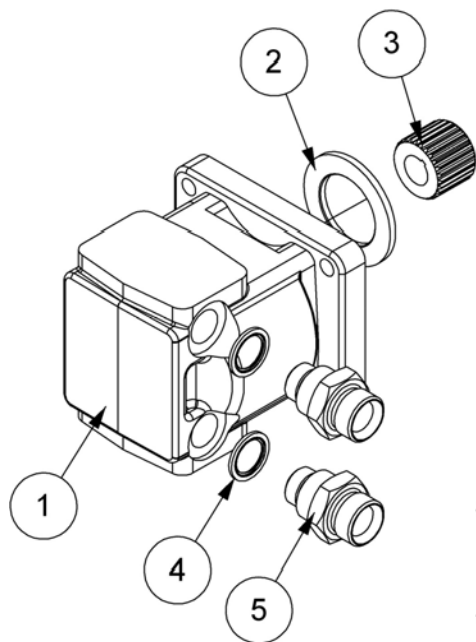

JIC Adaptors –
Module 22495.16

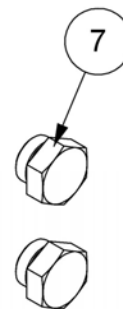
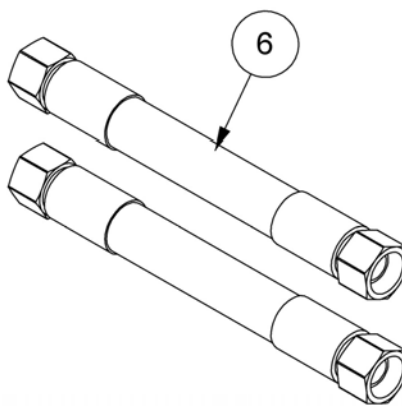

REF.	ANTAL	BEST.nr	BESKRIVNING
		22495.06	100LPM DRIVE MODULE 54HP
		22495.05	125LPM DRIVE MODULE 65HP
1	1	8301302	MOTOR (BACK PORTED) - 54HP
	1	8301304	MOTOR (BACK PORTED) - 65HP
2	1	7190015	LOCATING WASHER
3	1	43390.02	DRIVE COUPLING - 27 TOOTH
4	2	8650106	BONDED SEAL
5	2	8581295	ADAPTOR
6	2	8501254	HOSE - 1" BSP FS/FS x 1900mm
7	2	05.433.03	PLUG

REF.	ANTAL	BEST.nr	BESKRIVNING
		22495.16	75LPM DRIVE MODULE 45HP (JIC)
1	1	8301303	MOTOR (BACK PORTED) - 45HP
2	1	7190015	LOCATING WASHER
3	1	43390.02	DRIVE COUPLING - 27 TOOTH
4	2	8650106	BONDED SEAL
5	2	8581167	ADAPTOR (JIC)
6	2	08.960.32	HOSE - 3/4" BORE 1.1/16" FS/FS x 2100mm

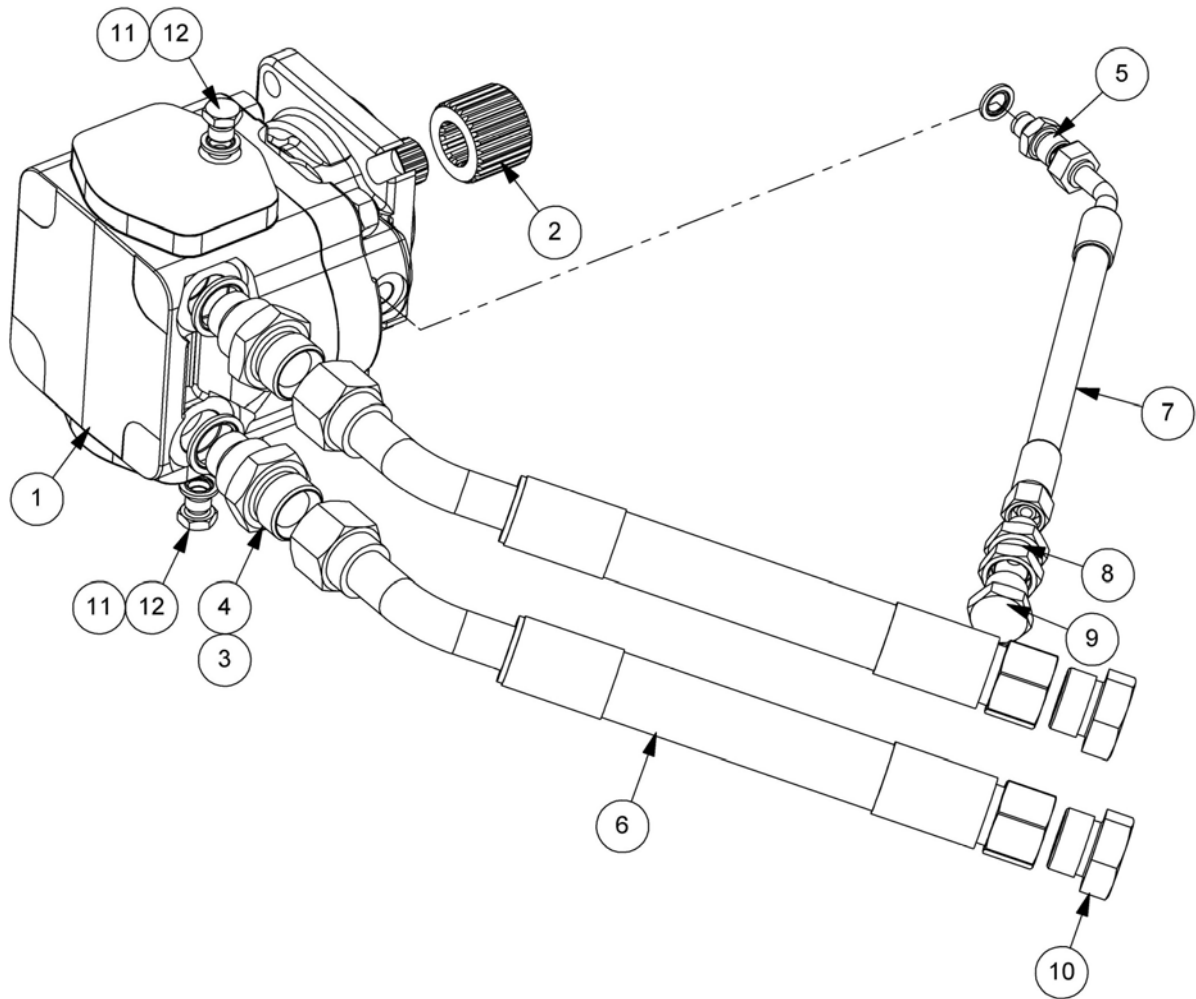

REF.	ANTAL	BEST.nr	BESKRIVNING
		22495.01	125LPM DRIVE MODULE (85HP)
1	1	8301313	HIGH PRESSURE MOTOR (45cc)
2	1	43390.03	DRIVE COUPLING
3	2	8650106	BONDED SEAL
4	2	8581295	ADAPTOR
5	1	01.099.01	ADAPTOR
6	2	8501401	HOSE - 1" BSP FS/F135 x 1900mm
7	1	10.030.29	HOSE - 3/8" BSP FS/F135 x 1900mm
8	1	8581544	SWIVEL ADAPTOR
9	1	8581351	BLANKING PLUG
10	2	05.433.03	PLUG
11	3	8650102	BONDED SEAL
12	2	520378	ADAPTOR PLUG

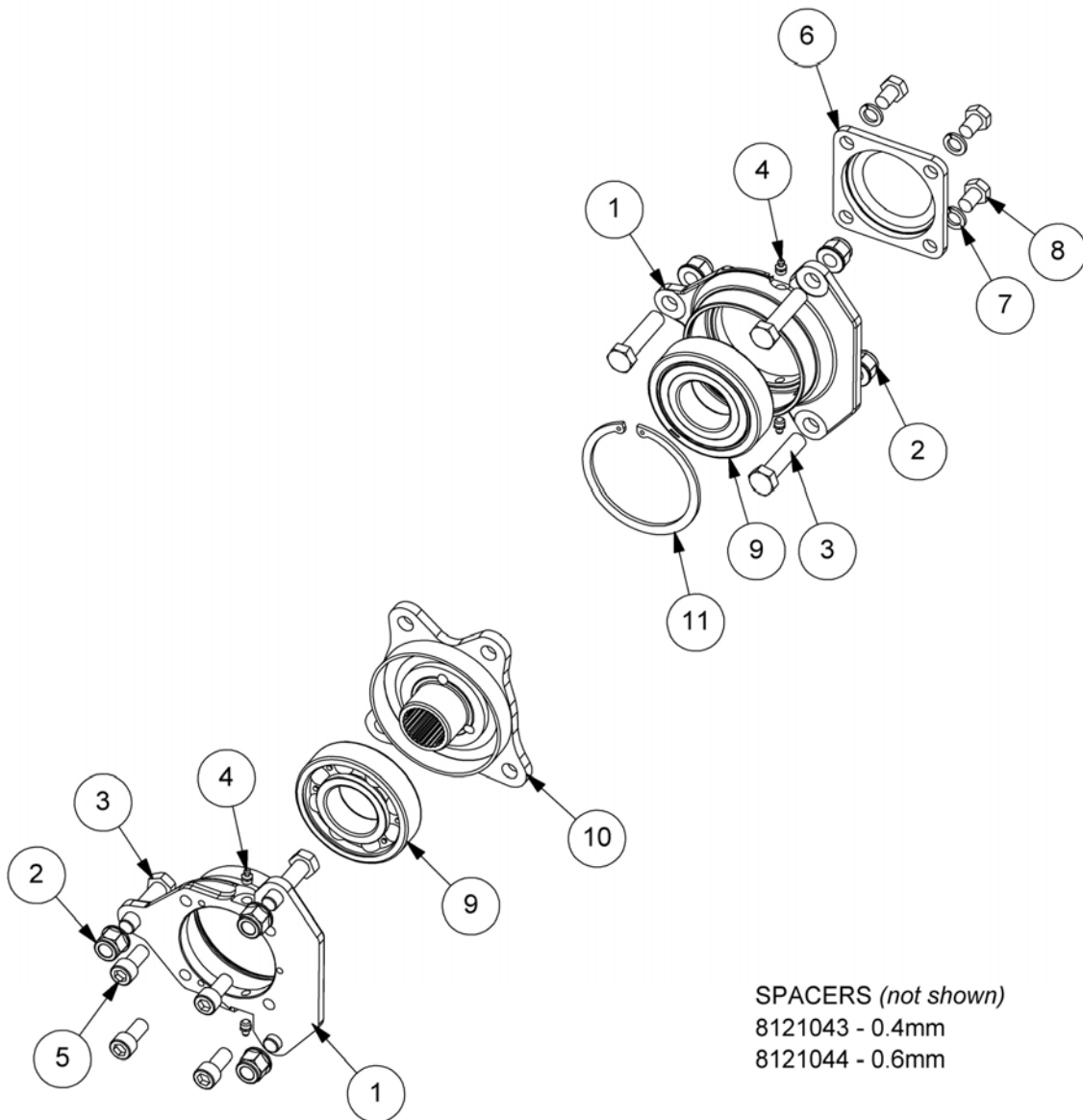

REF.	ANTAL	BEST.nr	BESKRIVNING
		22498.01	QUAD DRIVE MODULE
1	2	7190367	BEARING HOUSING
2	6	9100024	SELF-LOCKING FLANGE NUT
3	6	9200024	BOLT
4	4	0901121	GREASE NIPPLE
5	4	9300171	CAPSCREW
6	1	43390.04	BEARING END PLATE
7	4	05.282.08	SPRING WASHER
8	4	9313047	SETSCREW
9	2	0600018	BALL BEARING
10	1	22269.02	DRIVE HUB
11	1	7190022	INTERNAL CIRCLIP
12	5	8121044	SHIM-0.6mm
13	5	8121043	SHIM-0.4mm

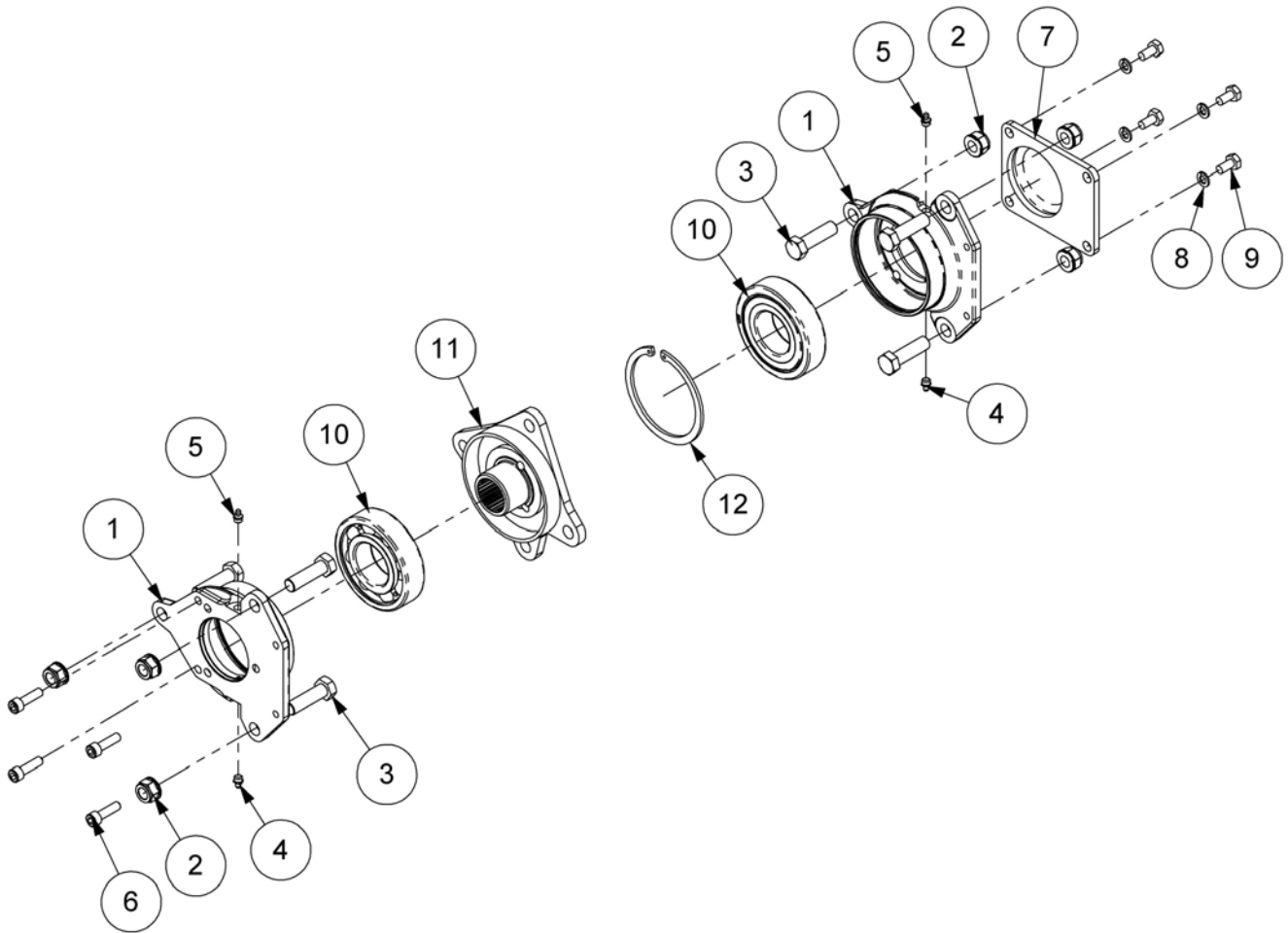

REF.	ANTAL	BEST.nr	BESKRIVNING
		22498.03	MULTICUT QUAD DRIVE ASSEMBLY
1	2	7190261	BEARING HOUSING
2	6	9100024	SELF-LOCKING FLANGE NUT
3	6	9200023	BOLT
4	2	0901121	GREASE NIPPLE - STRAIGHT
5	2	0901125	GREASE NIPPLE - 45°
6	4	9300144	CAPSCREW
7	1	7190292	COVER PLATE
8	4	9100205	SPRING WASHER
9	4	9313045	SETSCREW
10	2	0600018	BALL BEARING
11	1	22269.02	DRIVE HUB - QUAD DRIVE
12	1	7190022	INTERNAL CIRCLIP
13	<i>as req'd</i>	8121043	SHIM - 0.4mm
14	<i>as req'd</i>	8121044	SHIM - 0.6mm

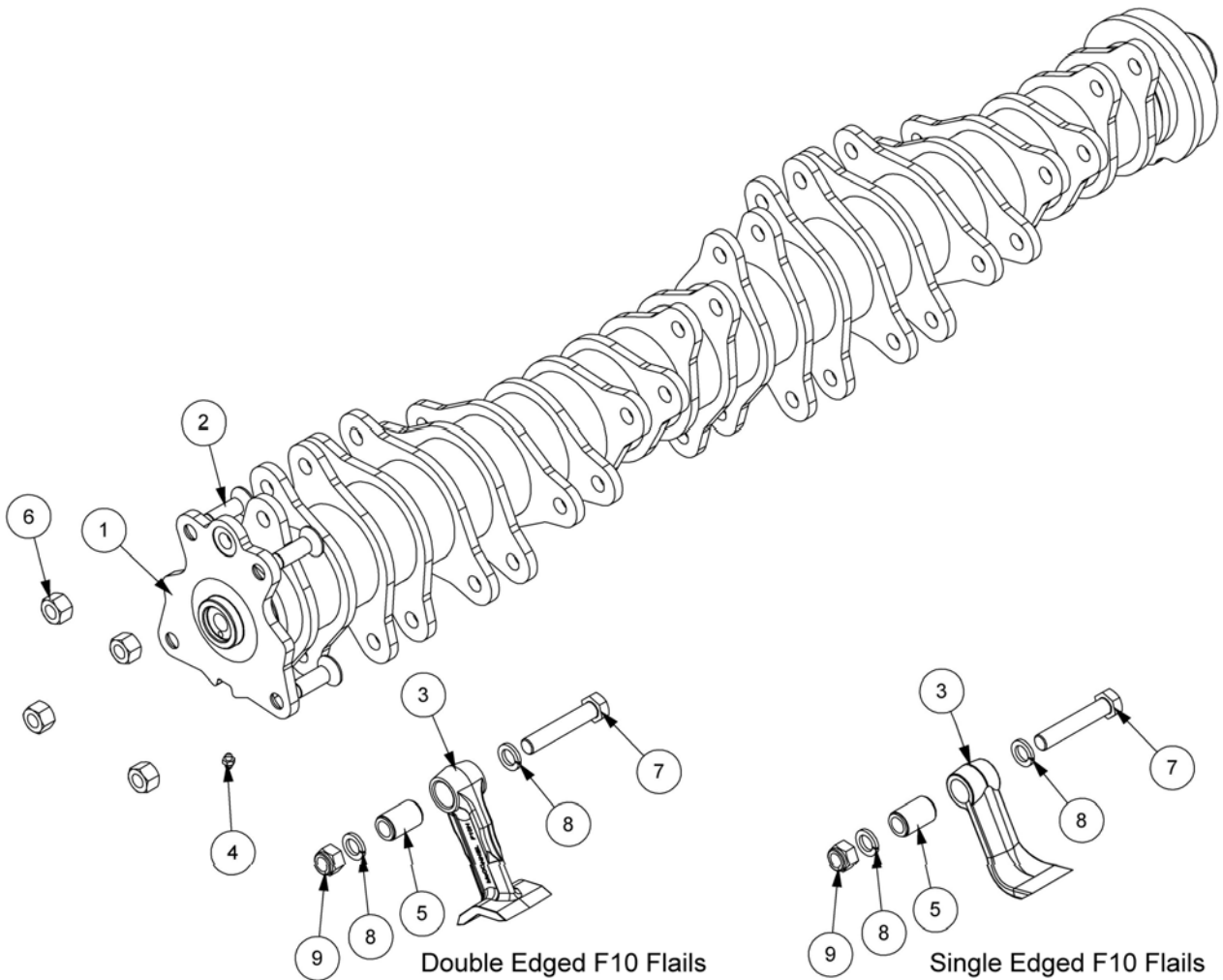

REF.	ANTAL	BEST.nr	BESKRIVNING
		22497.01	1.2M QUAD DRIVE ROTOR (F10DE FLAILS)
		22497.02	1.2M QUAD DRIVE ROTOR (F10SE FLAILS)
1	1	22269.01	ROTOR - 1.2M QUAD DRIVE
2	4	9353097	CAPSCREW
3	24	7314366D	F10H DOUBLE EDGED FLAIL (CAST)
	24	7390276	F10 SINGLE EDGED FLAIL (CAST)
4	1	0901161	GREASE NIPPLE
5	24	7314223	FLAIL PIVOT BUSH (NARROW)
6	4	9143007	SELF-LOCKING NUT
7	24	7314201	SPECIAL BOLT (UNF)
8	48	0100206	SPRING WASHER
9	24	0141006	CLEVELOC NUT (UNF)

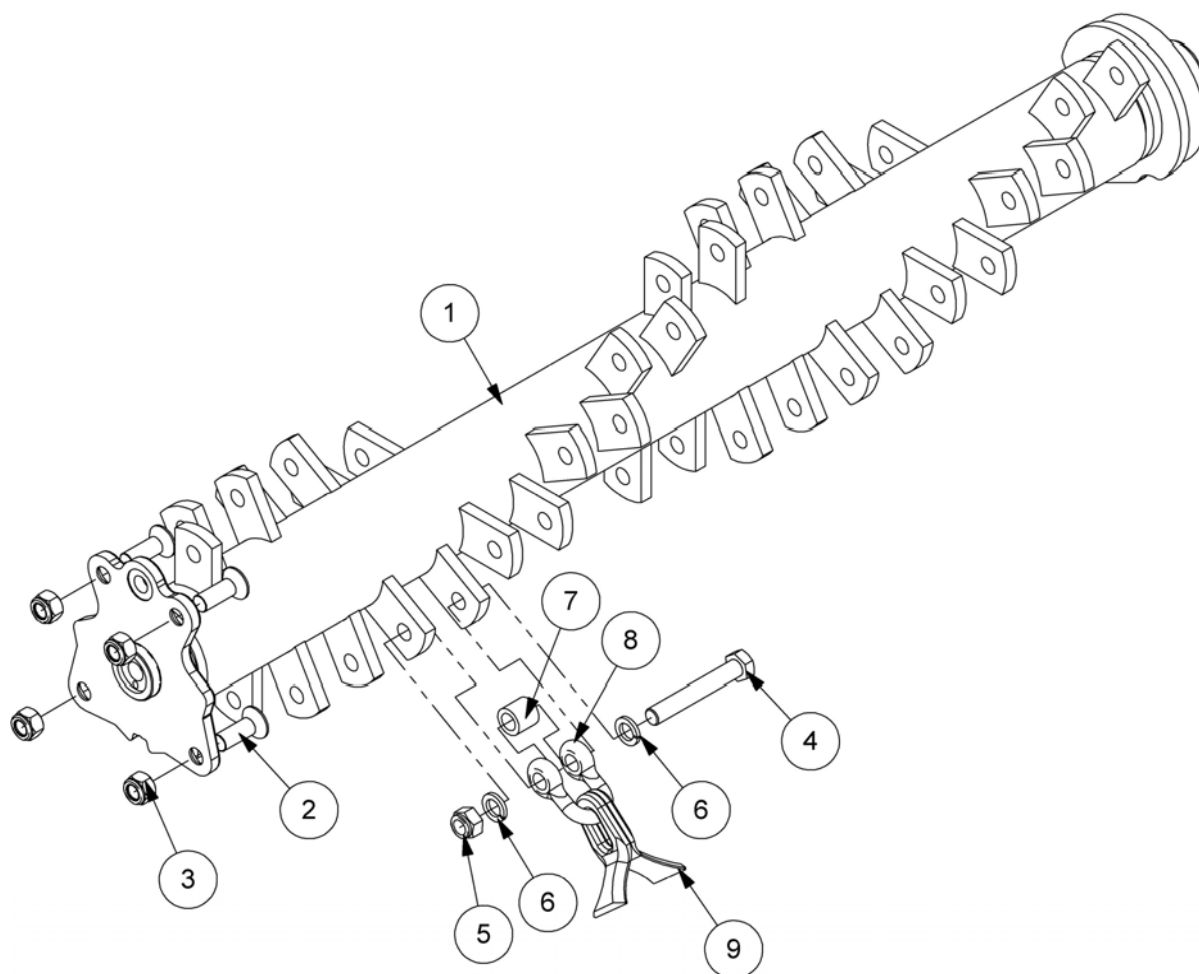

REF.	ANTAL	BEST.nr	BESKRIVNING
		22497.09	1.2M ROTOR MODULE
1	1	22269.14	1.2M QUAD LUGGED ROTOR
2	4	9353097	SKT CSK CAPSCREW 3
	4	9163007	NYLOC NUT M16
4	24	7390006	SPECIAL BOLT
5	24	0141006	UNF CLEVELOC NUT
6	48	0100206	SPRING WASHER
7	24	7390018	SLEEVE
8	24	7390013	SHACKLE
9	48	41654.01	FLAIL (FLARED)

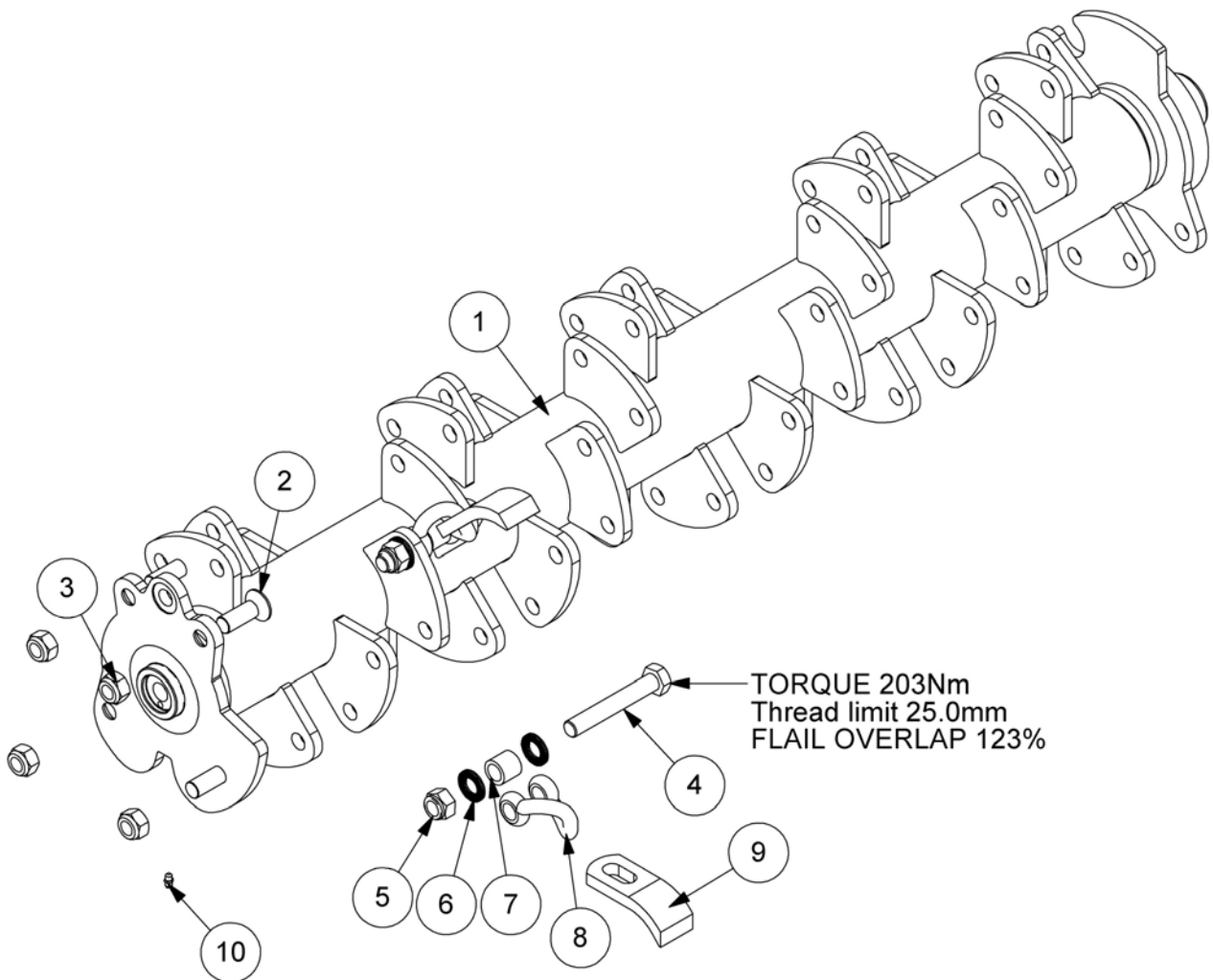

REF.	ANTAL	BEST.nr	BESKRIVNING
		22497.41	1.2M ROTOR ASSEMBLY
1	1	22269.16	ROTOR 1.2M QUAD DRIVE (36 ROW)
2	4	9353097	SOCKET CAPSCREW
3	4	9163007	NYLOC NUT
4	36	7390006	SPECIAL BOLT
5	36	0141006	CLEVELOC NUT
6	72	B001017	NORDLOCK WASHER
7	36	42889.06	SHACKLE SPACER
8	36	42889.01	TWISTED SHACKLE
9	36	21366.01	J FLAIL
10	1	0901161	GREASE NIPPLE.

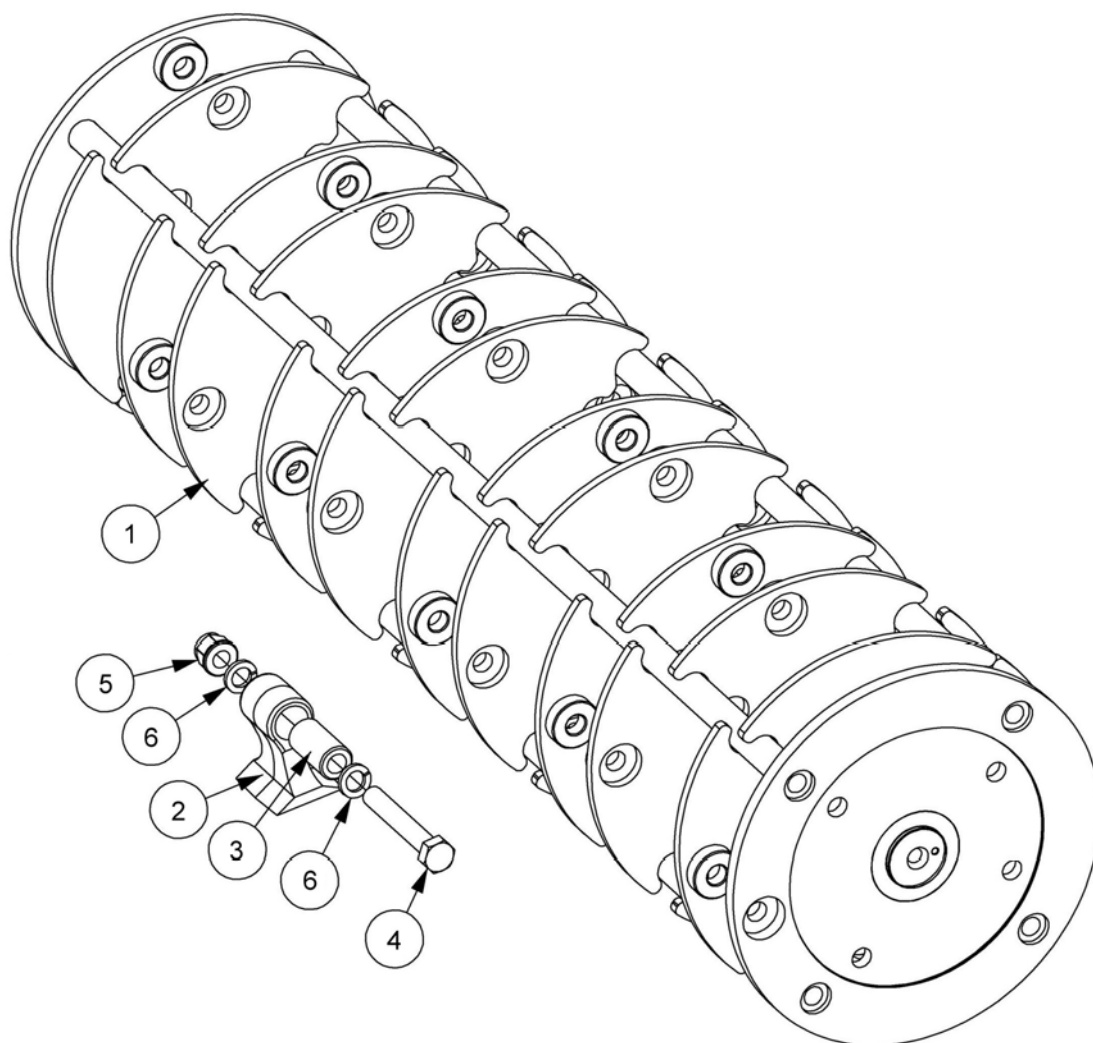

REF.	ANTAL	BEST.nr	BESKRIVNING
			1.2M OMEGA QUAD DRIVE ROTOR
1	1	22269.04	1.2M OMEGA ROTOR
2	20	7190464	OMEGA FLAIL
3	20	7190117	FLAIL PIVOT BUSH
4	20	7390006	SPECIAL FLAIL BOLT
5	20	0141006	SELF-LOCKING NUT
6	40	0100206	SPRING WASHER

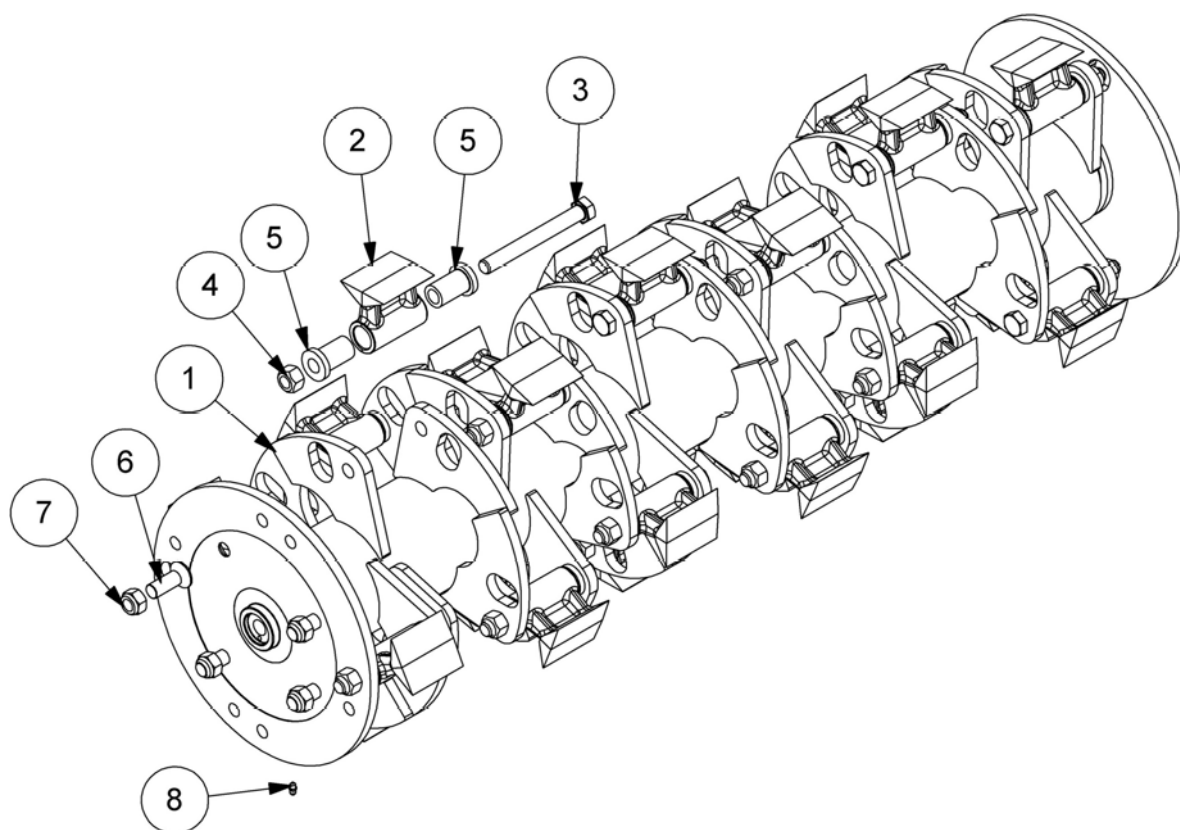

REF.	ANTAL	BEST.nr	BESKRIVNING
		22497.48	1.2M ROTOR ASSEMBLY
1	1	22269.19	1.2m BUSHMASTER ROTOR
2	24	46401.01	FLAIL (BUSHMASTER)
3	24	05.775.14	BOLT
4	24	T7942	SELF-LOCKING NUT
5	48	42598.03	PIVOT COLLAR
6	4	9353097	CAPSCREW
7	4	9163007	NYLOC NUT
8	1	0901161	GREASE NIPPLE

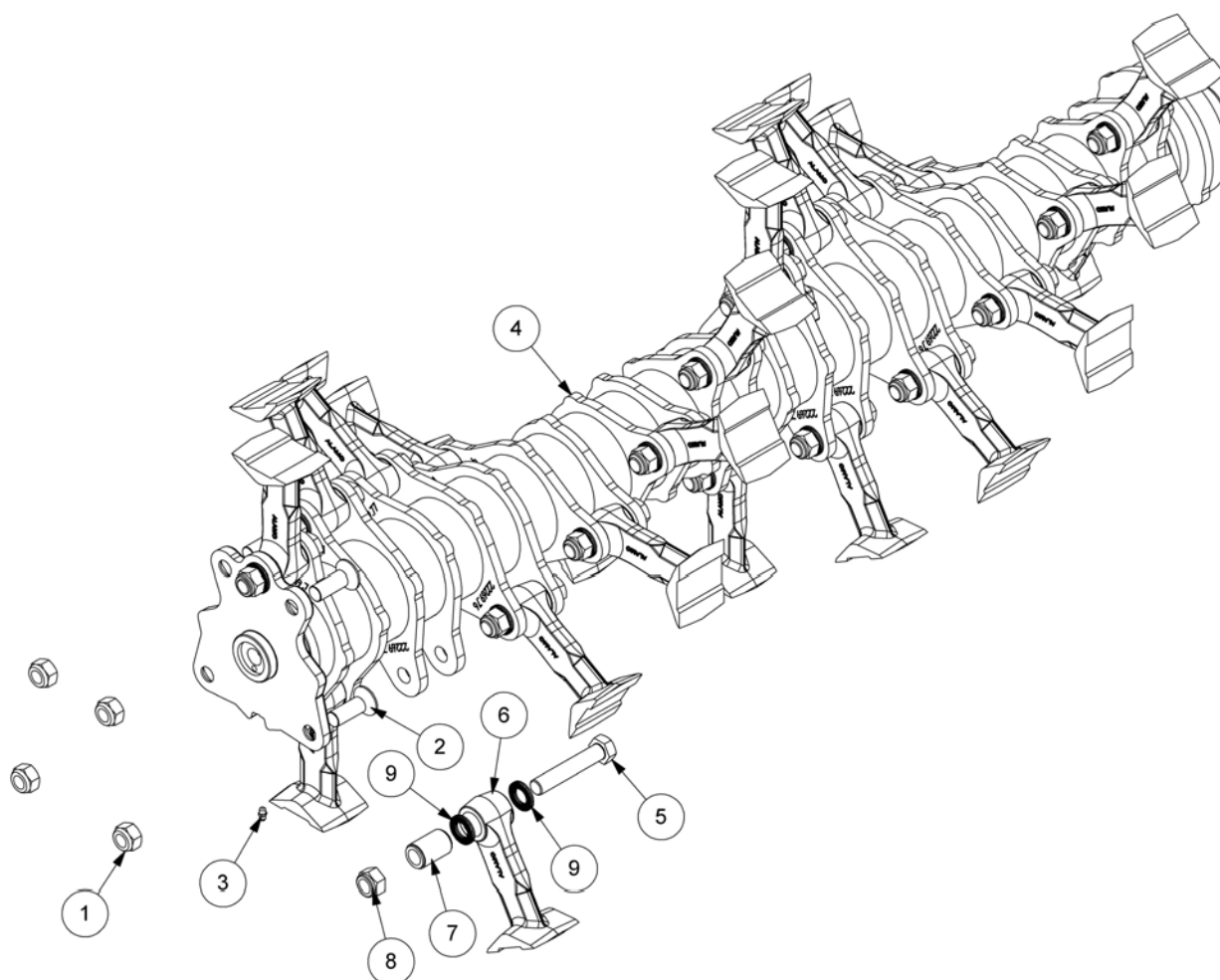

REF.	ANTAL	BEST.nr	BESKRIVNING
		22497.85	1.2M ROTOR ASSEMBLY
1	4	9163007	NYLOC NUT
2	4	9353097	CAPSCREW
3	1	0901161	GREASE NIPPLE
4	1	22269.20	1.2M QUAD ROTOR
5	24	7314201	UNF SPECIAL BOLT
6	24	41391.01	FLAIL - FORGED F10
7	24	7314223	FLAIL PIVOT BUSH (NARROW)
8	24	0141006	UNF CLEVELOC NUT
9	48	B001017	NORDLOCK WASHER

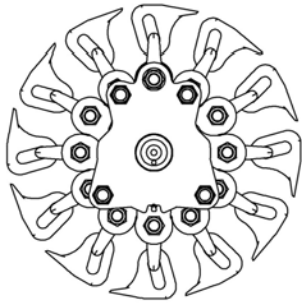

NOTE ORIENTATION OF FLAILS
IN RELATION TO DRIVE END

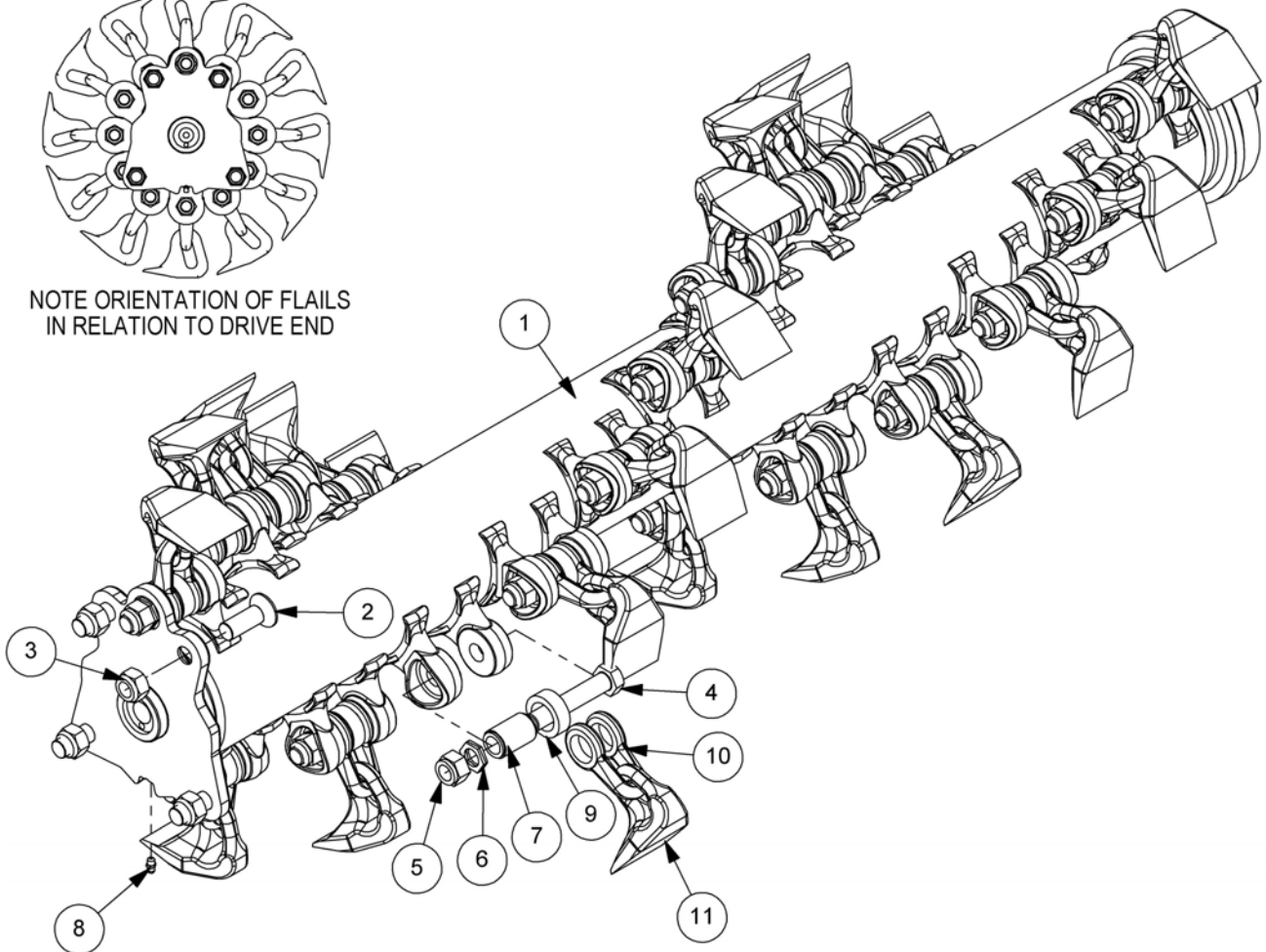

REF.	ANTAL	BEST.nr 22497.67	BESKRIVNING 1.2M TUFFCUT ROTOR ASSEMBLY
1	1	23225	1.2M CAST LUG ROTOR
2	4	9353097	CAPSCREW
3	4	9163007	NYLOC NUT
4	24	7314201	UNF SPECIAL BOLT
5	24	0141006	UNF CLEVELOC NUT
6	24	9100507	LOCKING WASHER (PAIR)
7	24	7314223	FLAIL PIVOT BUSH (NARROW)
8	1	0901161	GREASE NIPPLE
9	24	7190172	SPACER
10	24	7190175	SHACKLE
11	24	7190462	BOOT FLAIL

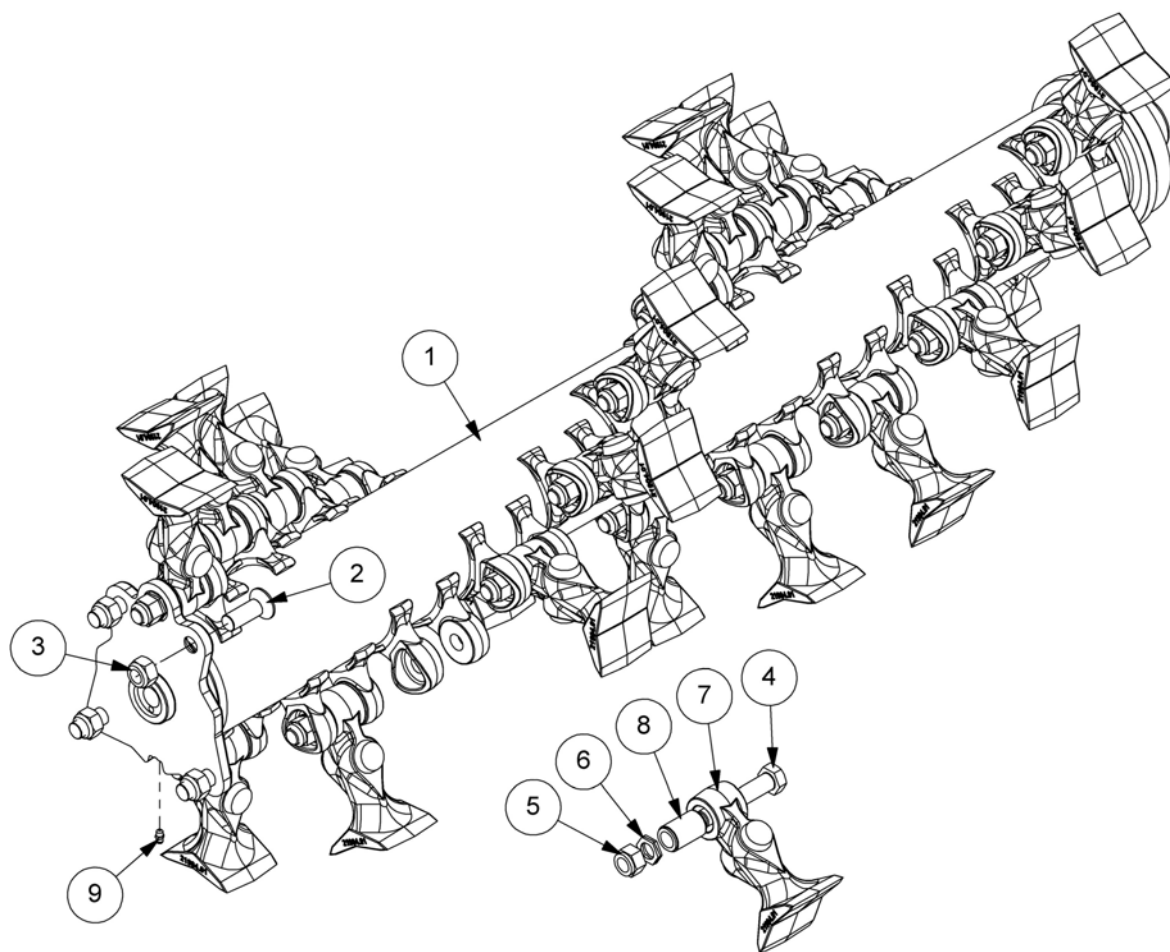

REF.	ANTAL	BEST.nr	BESKRIVNING
		22497.86	1.2M TUFFCUT ROTOR ASSEMBLY
1	1	23225.01	1.2M QD CAST LUG ROTOR
2	4	9353097	CAPSCREW
3	4	9163007	NYLOC NUT
4	24	7314201	UNF SPECIAL BOLT
5	24	0141006	UNF CLEVELOC NUT
6	24	9100507	LOCKING WASHER (PAIR)
7	24	21904.02	CAST FLAIL
8	24	7314223	FLAIL PIVOT BUSH (NARROW)
9	1	0901161	GREASE NIPPLE

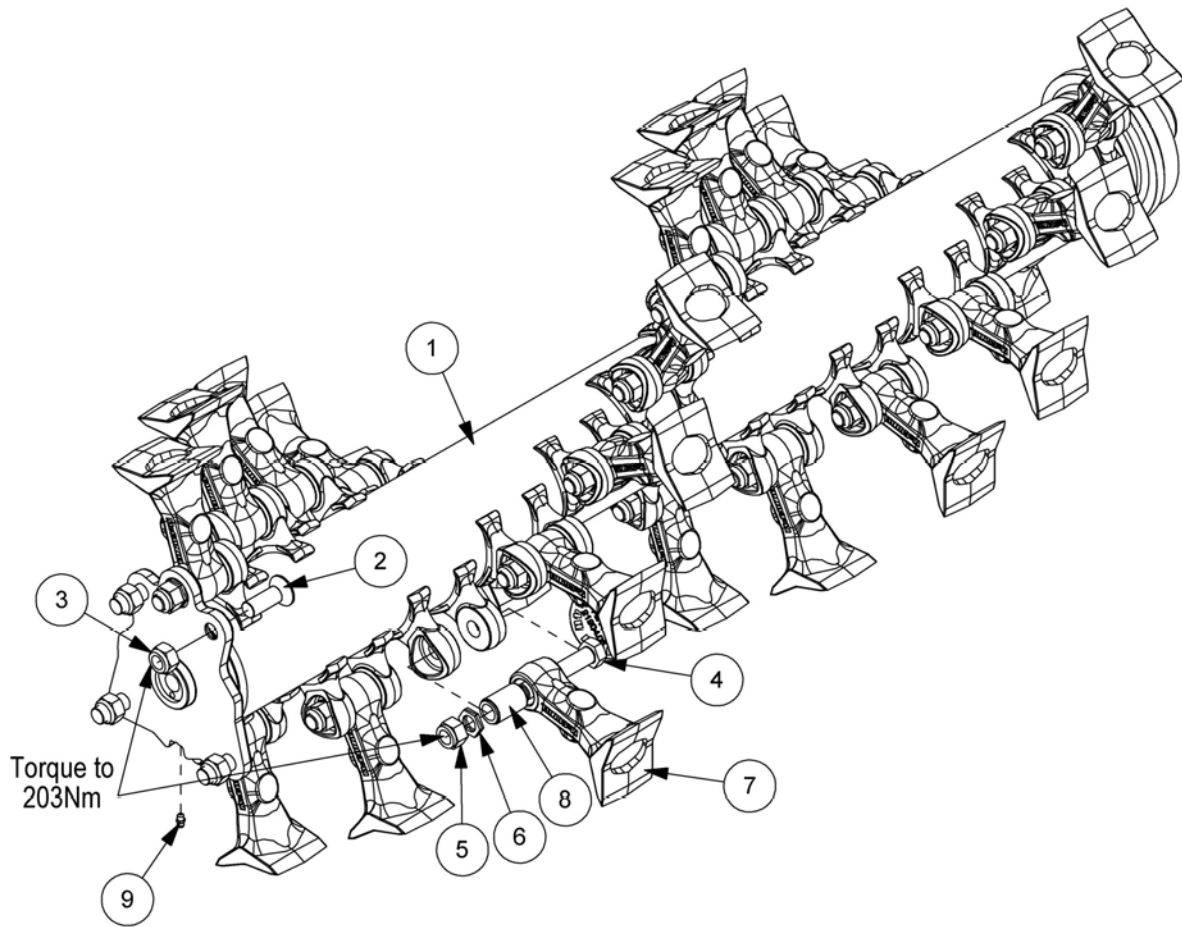

REF.	ANTAL	BEST.nr	BESKRIVNING
		22497,96	1.2M ROTOR MODULE
1	1	23225.01	1.2M QD CAST LUG ROTOR
2	4	9353097	SOCKET CAPSCREW
3	4	9163007	NYLOC NUT
4	24	7314201	UNF SPECIAL BOLT
5	24	0141006	UNF CLEVELOC NUT
6	24	9100507	LOCKING WASHER (PAIR)
7	24	21904.05	CAST FLAIL - F14H
8	24	7314223	FLAIL PIVOT BUSH (NARROW)
9	1	0901161	GREASE NIPPLE
10	1	21365.06	DECAL

Moduler: Slagor enheter

F10 D.E. Cast Flail
(Part No. 7314366D)

HEDGE



FIXINGS

- ← Bolt: 7314201 →
- ← Bush: 7314223 →
- ← Washer: 0100206 →
- ← Locknut: 0141006 →

F10 D.E. Forged Flail
(Part No. 41391.02)

HEDGE

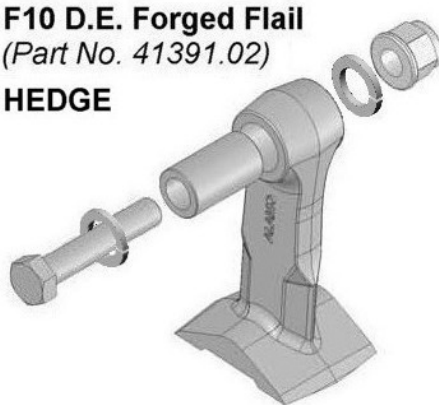

F10 S.E. Cast Flail
(Part No. 7390276)

HEDGE

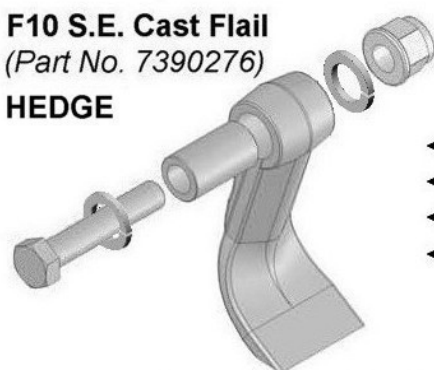

FIXINGS

- ← Bolt: 7314201 →
- ← Bush: 7314223 →
- ← Washer: 0100206 →
- ← Locknut: 0141006 →

F16 D.E. Cast Flail
(Part No. 21904.02)

HEDGE

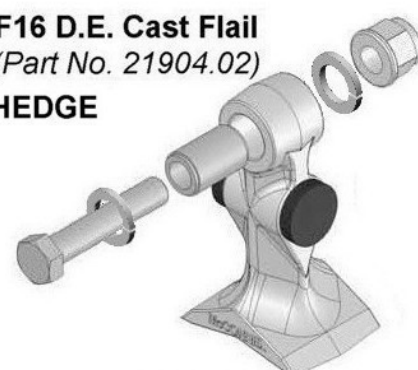

D.E. Omega Flail
(Part No. T1840572)

HEDGE



FIXINGS

- ← Bolt: 7390006 →
- ← Bolt: 7314201 →
- ← Bush: 21215.02 →
- ← Bush: 7314223 →
- ← Washer: 0100206 →
- ← Locknut: 0141006 →

Omega Rotor use only

F14 D.E. Cast Flail
(Part No. 21904.05)

HEDGE



F10 Grass Flail
(Part No. 7190315)

GRASS

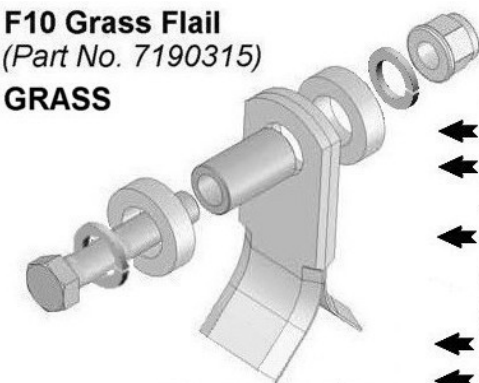

FIXINGS

- ← Bolt: 7314201 →
- ← Bush: 21215.02 →
- ← Bush: 7314223 →
- ← Spacer: 7190010 →
- ← Spacer: 7190172 →
- ← Shackle: 7190175 →
- ← Washer: 0100206 →
- ← Locknut: 0141006 →

Forged Boot Flail
(Part No. 7190462)

UNIVERSAL

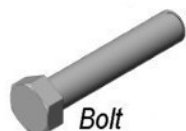
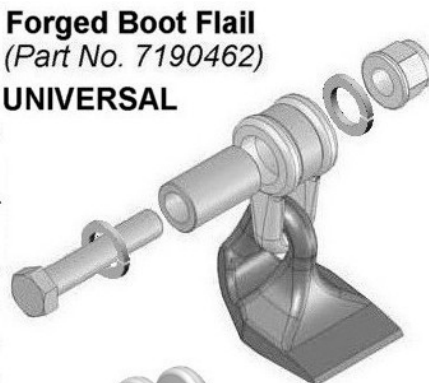

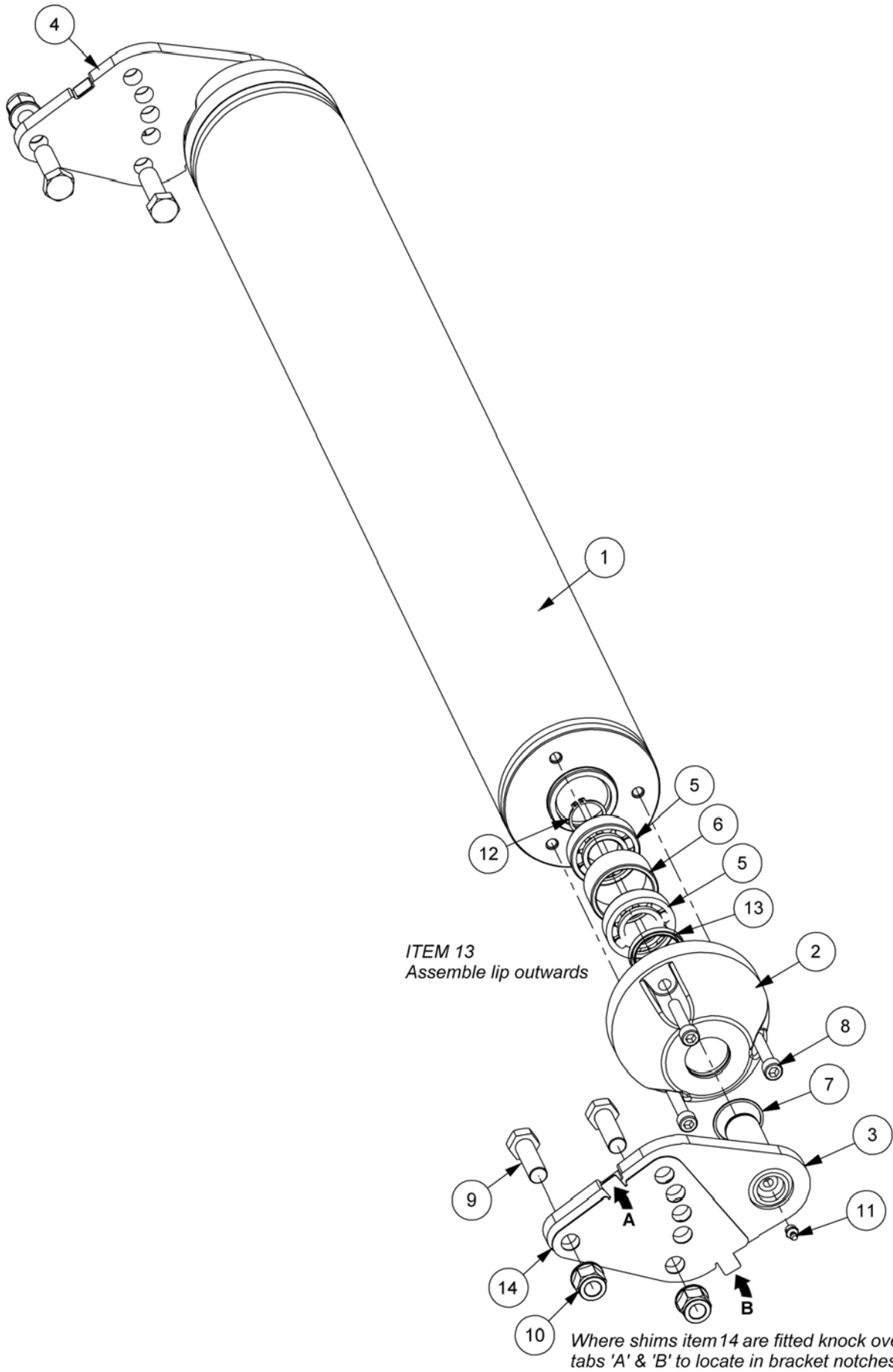

REF.	ANTAL	BEST.nr 21523.08	BESKRIVNING ROLLER ASSEMBLY
1	1	21394.03	1.2M ROLLER
2	2	21394.32	ROLLER END CAP
3	1	21524.12	ROLLER BRACKET - L/H (<i>Std. Position</i>)
4	1	21524.13	ROLLER BRACKET - R/H (<i>Std. Position</i>)
5	4	0600111	BALL BEARING
6	2	21523.31	BEARING SPACER
7	2	0402240	INTERNAL SPIROLOX RING
8	6	9343105	CAPSCREW
9	4	9200031	BOLT
10	4	9100024	SELF-LOCKING FLANGE NUT
11	2	0901121	GREASE NIPPLE
12	2	0401230	EXTERNAL CIRCLIP
13	2	8629239	ROTARY SHAFT SEAL
14	<i>as req'd</i>	42257.10	SHIM - 1.2mm

Note: Roller Brackets Items 3 & 4 are swappable L/H to R/H on the roller to give various differing height settings - the illustration show the brackets assembled in the standard position with the longer edge notch upwards. When assembled the opposite way with the longer edge notch downwards it is referred to as the alternate position.

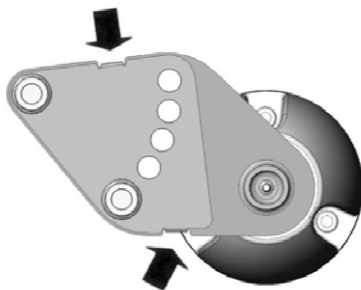

Standard Roller Position

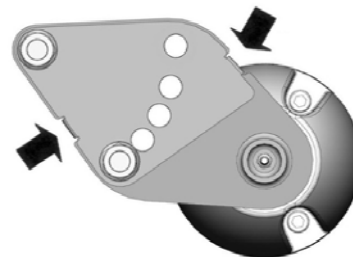

Alternate Roller Position

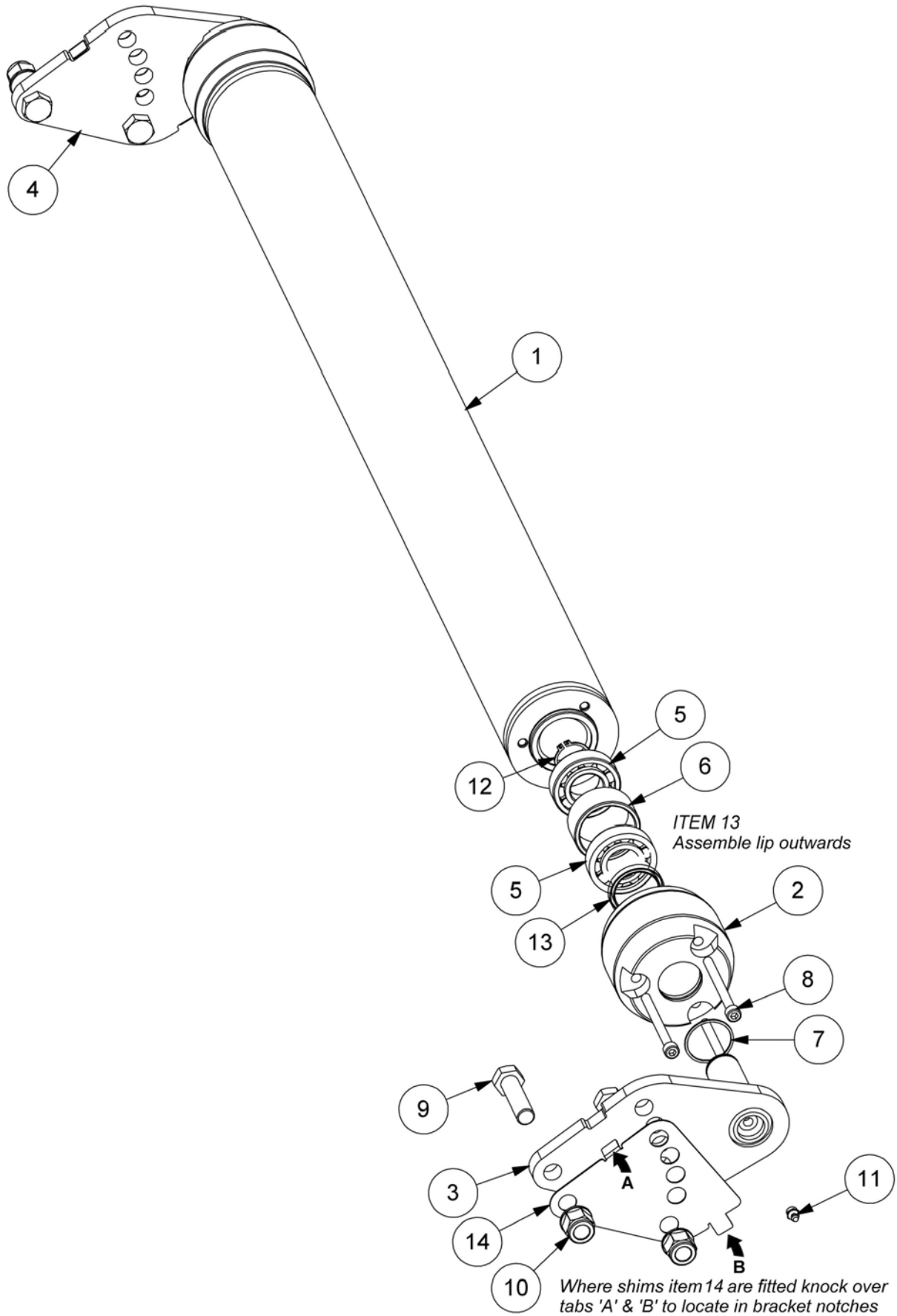

REF.	ANTAL	BEST.nr	BESKRIVNING
		21523.45	1.2M ROLLER ASSEMBLY
1	1	21394.09	1.2M ROLLER
2	2	21394.47	ROLLER END CAP
3	1	21524.12	ROLLER BRACKET - L/H (<i>Std. Position</i>)
4	1	21524.13	ROLLER BRACKET - R/H (<i>Std. Position</i>)
5	4	0600111	BALL BEARING
6	2	21523.31	BEARING SPACER
7	2	0402240	INTERNAL SPIROLOX RING
8	6	9343184	CAPSCREW
9	4	9200031	BOLT
10	4	9100024	S/LOCKING FLANGE NUT
11	2	0901121	GREASE NIPPLE
12	2	0401230	EXTERNAL CIRCLIP
13	2	8629239	ROTARY SHAFT SEAL
14	2	42257.10	SHIM - 1.2mm

Note: Roller Brackets Items 3 & 4 are swappable L/H to R/H on the roller to give various differing height settings - the illustration show the brackets assembled in the standard position with the longer edge notch upwards. When assembled the opposite way with the longer edge notch downwards it is referred to as the alternate position.

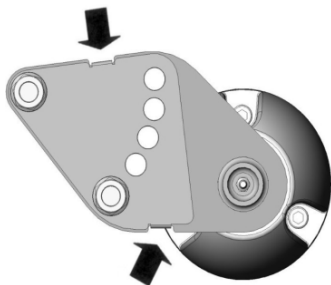

Standard Roller Position

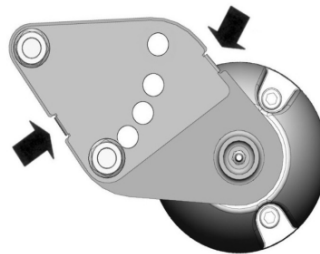

Alternate Roller Position

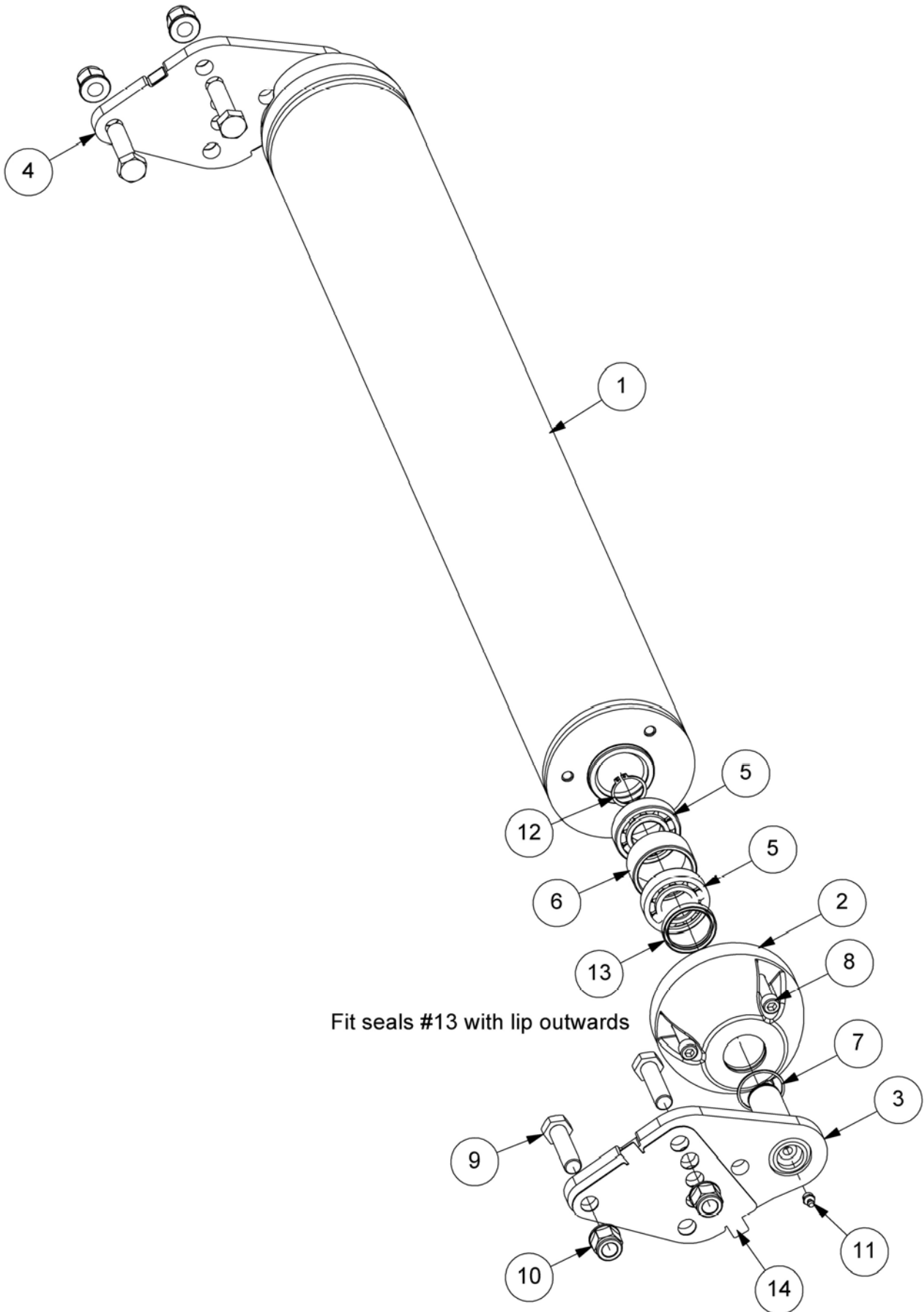

REF.	ANTAL	BEST.nr	BESKRIVNING
		21523.49	1.2M ROLLER ASSEMBLY
1	1	21394.03	1.2M ROLLER
2	2	21394.32	ROLLER END CAP
3	1	21524.14	ROLLER BRACKET - L/H (<i>Std. Position</i>)
4	1	21524.15	ROLLER BRACKET - R/H (<i>Std. Position</i>)
5	4	0600111	BALL BEARING
6	2	21523.31	BEARING SPACER
7	2	0402240	INTERNAL SPIROLOX RING
8	6	9343105	CAPSCREW
9	4	9200031	BOLT
10	4	9100024	S/LOCKING FLANGE NUT
11	2	0901121	GREASE NIPPLE
12	2	0401230	EXTERNAL CIRCLIP
13	2	8629239	ROTARY SHAFT SEAL
14	2	42257.10	SHIM

Note: Roller Brackets Items 3 & 4 are swappable L/H to R/H on the roller to give various differing height settings - the illustration show the brackets assembled in the standard position with the longer edge notch upwards. When assembled the opposite way with the longer edge notch downwards it is referred to as the alternate position.

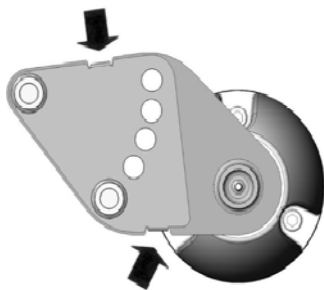

Standard Roller Position

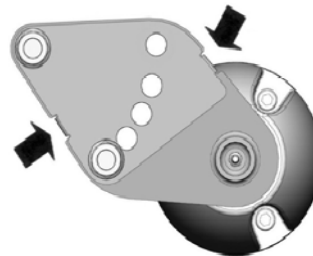

Alternate Roller Position

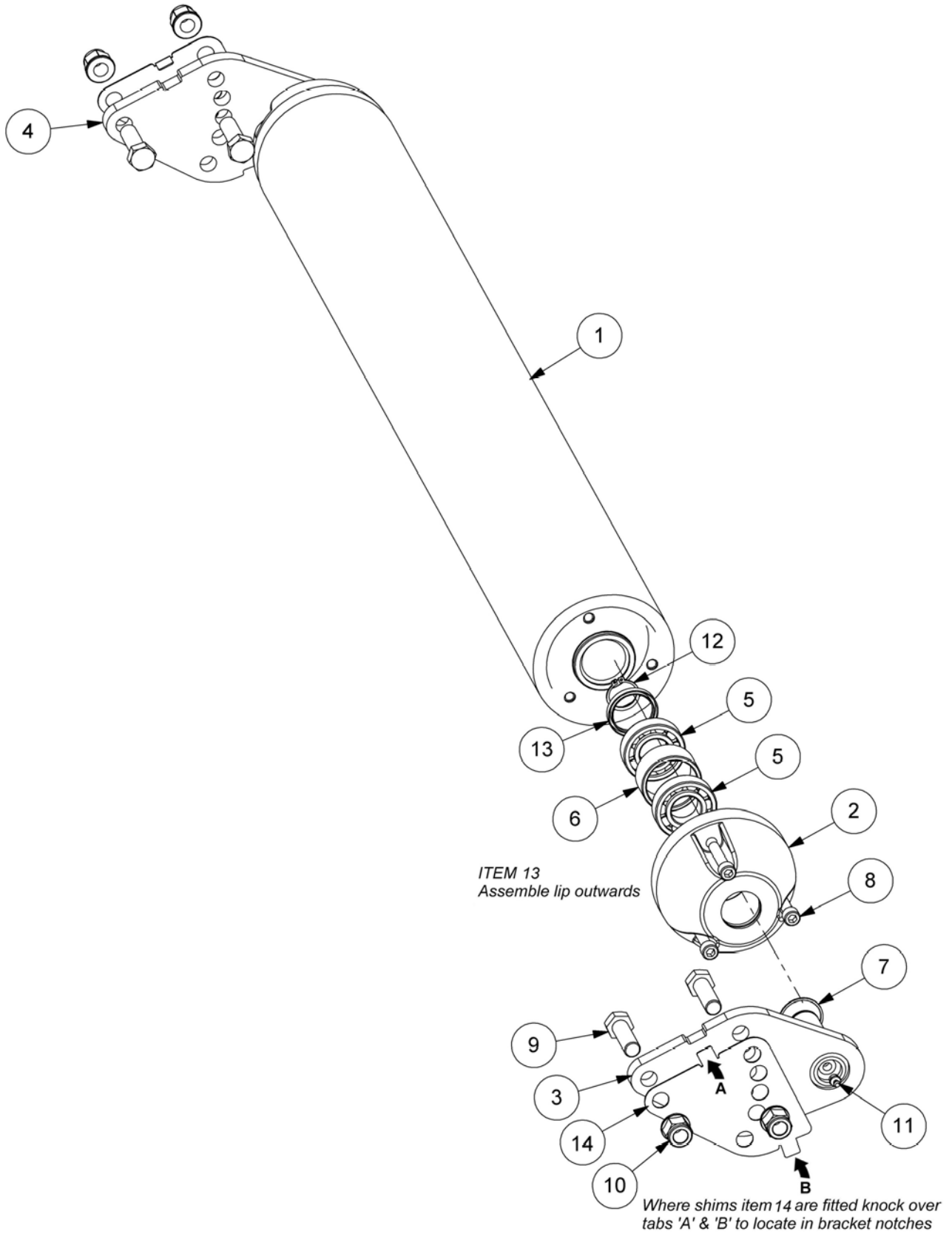

REF.	ANTAL	BEST.nr	BESKRIVNING
		22997.01	1.2M RUBBER ROLLER ASSEMBLY
1	1	21526.11	1.2m RUBBER ROLLER
2	2	21394.32	ROLLER END CAP
3	1	21524.12	ROLLER BRACKET - L/H (<i>Std. Position</i>)
4	1	21524.13	ROLLER BRACKET - R/H (<i>Std. Position</i>)
5	4	0600111	BALL BEARING
6	2	21523.31	BEARING SPACER
7	2	0402240	INT. SPIROLOX RING
8	6	9343105	CAPSCREW
9	4	9200025	BOLT
10	4	9100024	S/LOCKING FLANGE NUT
11	2	0901121	GREASE NIPPLE
12	2	0401230	EXTERNAL CIRCLIP
13	2	8629239	ROTARY SHAFT SEAL
14	<i>as req'd</i>	42257.10	SHIM - 1.2mm

Note: Roller Brackets Items 3 & 4 are swappable L/H to R/H on the roller to give various differing height settings - the illustration show the brackets assembled in the standard position with the longer edge notch upwards. When assembled the opposite way with the longer edge notch downwards it is referred to as the alternate position.

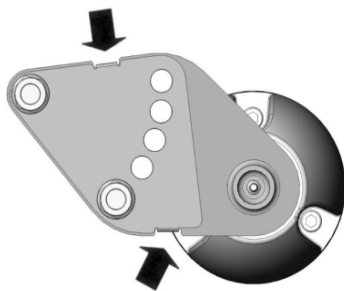

Standard Roller Position

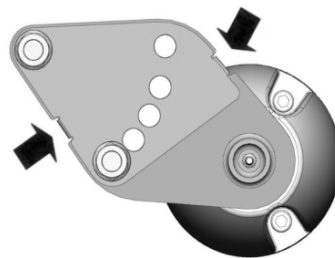

Alternate Roller Position

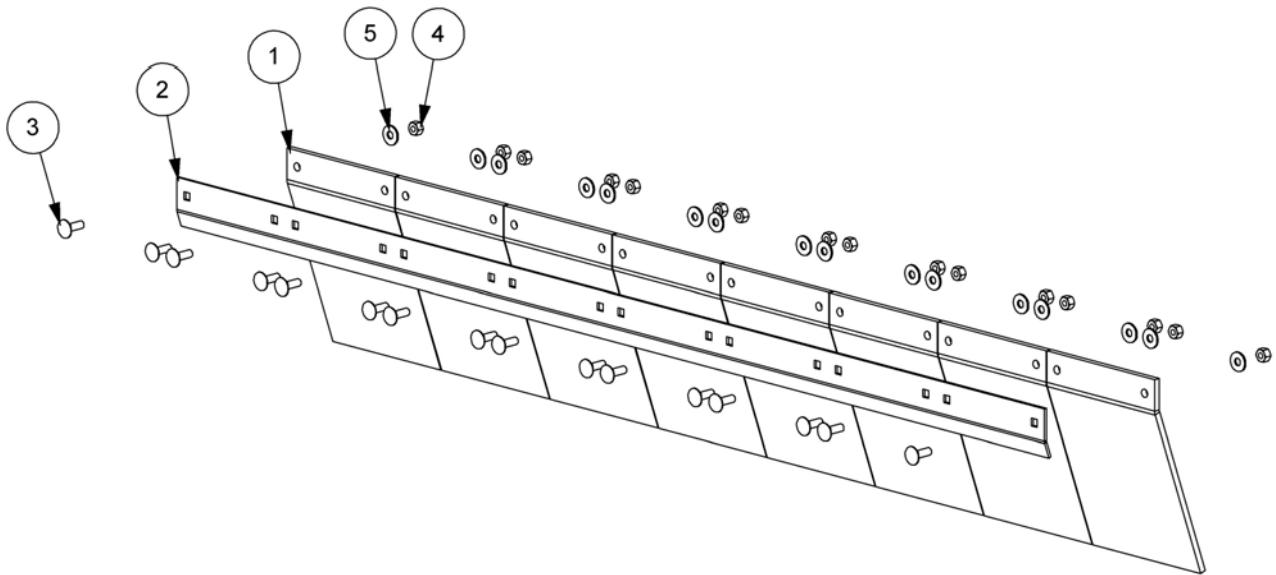

REF.	ANTAL	BEST.nr 7290375	BESKRIVNING
1	8	7290053	FRONT FLAP
2	1	7190304	CLAMP STRIP
3	16	9293054	CUP HEAD SCREW
4	16	9143004	SELF-LOCKING NUT
5	16	9100104	FLAT WASHER

Moduler: 21541.01

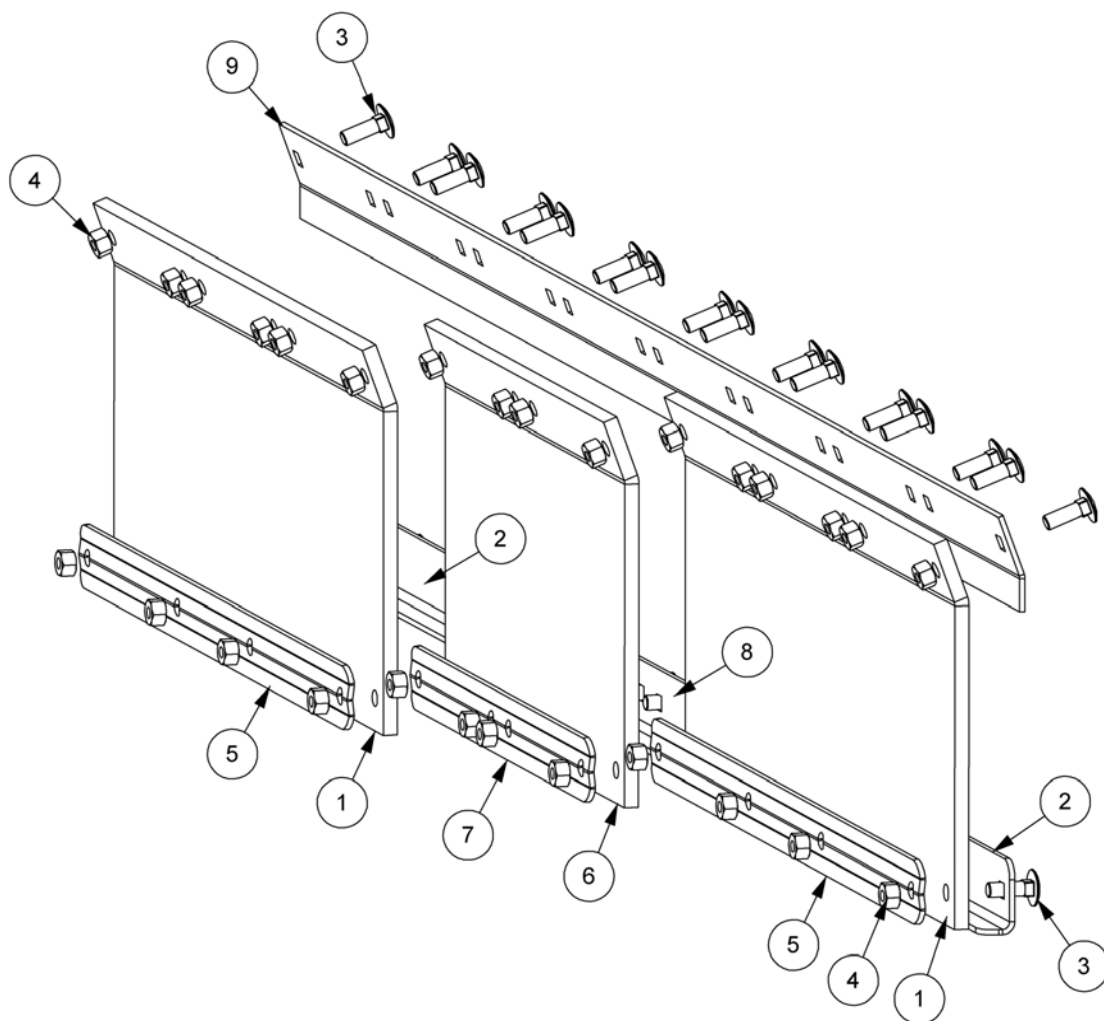

REF.	ANTAL	BEST.nr	BESKRIVNING
		21541.01	FRONT FLAP KIT (HEAVY DUTY)
1	2	21544.01	FRONT FLAP
2	2	21541.05	FLAP OUTER EDGE PLATE
3	28	9293054	CUP HEAD SQUARE SCREW
4	28	9143004	SELF-LOCKING NUT
5	2	21541.06	CLAMP PLATE
6	1	21544.02	MIDDLE FRONT FLAP
7	1	21541.08	MIDDLE CLAMP PLATE
8	1	21541.07	FLAP INNER EDGE PLATE
9	1	7190304	CLAMP STRIP

Moduler:

Den här sidan är avsiktligt tom

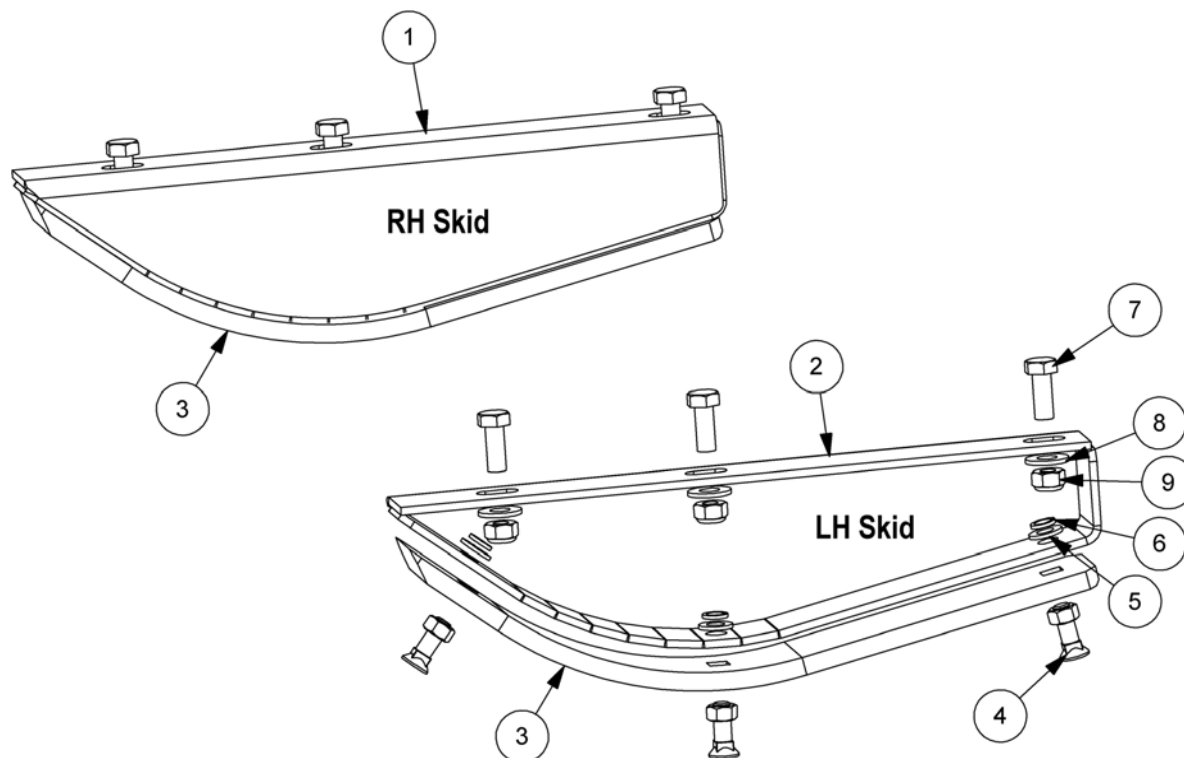

REF.	ANTAL	BEST.nr	BESKRIVNING
		7290384	SKID KIT
1	1	7290389	SKID RH
2	1	7290390	SKID LH
3	2	7290391	REPLACEABLE SKID SHOE
4	6	6012034	PLOUGH BOLT c/w NUT
5	6	0100104	FLAT WASHER
6	6	0100204	SPRING WASHER
7	6	9313066	SETSCREW
8	6	9100106	FLAT WASHER
9	6	9163006	NYLOC NUT



4

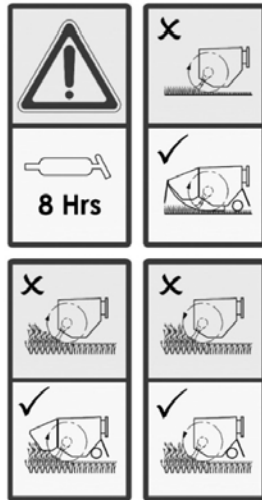

3

FLAIL PARTS INFORMATION

McConnel Flail Mowers use dynamically balanced and mated system components for Cutter Shafts, (Rotors) Knives (Flails), Knife hangers (Shackles) bolts, bushes Rollers, Drivetrain Components, Bearing Belts and Belt Pulleys. McConnel parts are made and tested to meet close-tolerance specifications of balance, quality and consistency that assure long, trouble-free service. "Will-Fit" parts do not ordinarily meet McConnel Standards and could reduce Mower performance, void warranties and present an increase in the safety hazard potential.

DON'T GAMBLE!
USE GENUINE McCONNEL SERVICE PARTS
See your McConnel dealer

5

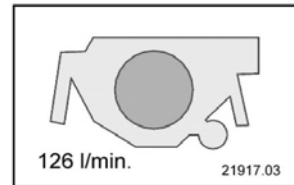

7

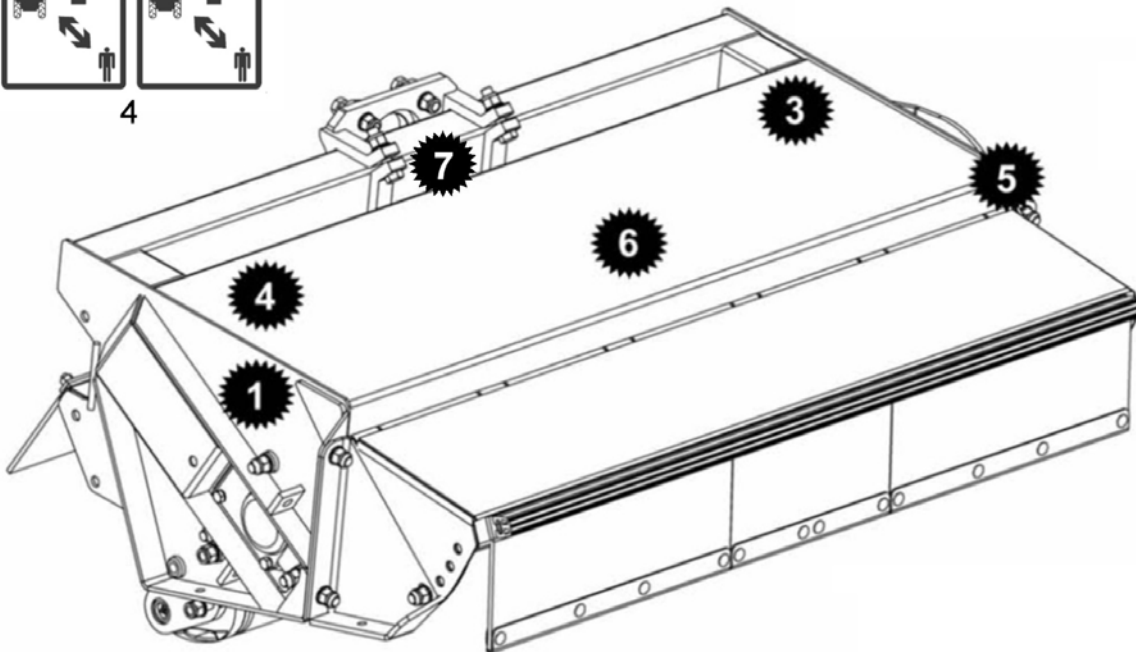

McCONNEL LTD
LUDLOW, SY8 1JL. PHONE: 01584 872131
FAX: 01584 878463
MADE IN ENGLAND

CE MACHINE _____
SERIAL No. _____
WEIGHT (KG) _____

1

McCONNEL

6

Moduler: 7390707, 7350709, 7350711

REF.	ANTAL	BEST.nr	BESKRIVNING
		7350711	45HP FLAILHEAD DECAL KIT
1	1	1335246	SERIAL No. PLATE
2	4	7103230	POP RIVET
3	1	1290738	DECAL - FLAILHEAD
4	1	09.821.35	DECAL - COMBINED EURO
5	1	1290392	DECAL - PARTS
6	1	1290527	DECAL - McCONNEL
7	1	21917.01	DECAL - 78 l/min (RED)

REF.	ANTAL	BEST.nr	BESKRIVNING
		7350707	54HP FLAILHEAD DECAL KIT
1	1	1335246	SERIAL No. PLATE
2	4	7103230	POP RIVET
3	1	1290738	DECAL - FLAILHEAD
4	1	09.821.35	DECAL - COMBINED EURO
5	1	1290392	DECAL - PARTS
6	1	1290527	DECAL - McCONNEL
7	1	21917.02	DECAL - 102 l/min (ORANGE)

REF.	ANTAL	BEST.nr	BESKRIVNING
		7350709	65HP FLAILHEAD DECAL KIT
1	1	1335246	SERIAL No. PLATE
2	4	7103230	POP RIVET
3	1	1290738	DECAL - FLAILHEAD
4	1	09.821.35	DECAL - COMBINED EURO
5	1	1290392	DECAL - PARTS
6	1	1290527	DECAL - McCONNEL
7	1	21917.03	DECAL - 126 l/min (GREEN)



McConnel Limited, Temeside Works, Ludlow, Shropshire SY8 1JL. England.
Telefon: +44 1584 873131. Fax: +44 1584 876463. www.mcconnel.com

Importör:

Närlant
IMPORT AB

Filarevägen 8, 703 75 Örebro
Tel: 019 – 603 60 60,
Fax: 019 – 31 20 96
Webbadress: www.narlant.se
E-post: info@narlant.se